

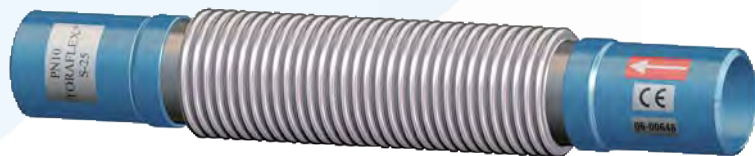

INSTALLATION, START-UP AND MAINTENANCE



S50



S25

METAL COMPENSATORS - TORAFLEX®

1.-GENERAL INFORMATION

TORAFLEX® Metal Compensators S25 PN10 & S50 PN16 are flexible unions used on rigid pipe work systems to absorb axial thermal movements. They consist of a corrugated Omega shaped bellow, with welded ends (S25) or flanged ends (S50), and an internal sleeve, which protects the bellow from wear and turbulences, and thus they are unidirectional. Additionally S50 type incorporates limit rods as standard.

The equipment is designed, manufactured and tested following procedures and high quality standards dictated by the EN ISO 9001.

Each manufacturing lot is strictly controlled by our Quality Section at the plant before dispatch. The equipment is inspected and tested to EN 12266-1. Extensive reports as per EN-10.204/3.1 are filled out and submitted to the Purchase under request prior dispatch. Moreover, witness testing carried out by Third Parties are arranged upon request at our modern Testing Facilities.

The equipments conform to Pressure Equipment Directive PED 97/23/CE, Category I for fluids Group no. 2 or acc. to Art. 3, Parr. 3 depending on application. For complete technical description please consult our Data Sheets at www.comeval.es or contact us at +34 961479011.

2. – GUARANTEE

TORAFLEX® Metal Compensators are guaranteed against any manufacturing default for a period of 12 months in accordance with Sound Engineering Practice and provided the application, installation and maintenance operations have been properly followed, according to our General Sales Terms.

No claims derived from wrong handling and/or lack of observation of General Technical Rules will be accepted.

The guarantee coverage does not apply to eventual damages caused by operation under duties other than described in our Data Sheets.

Our guarantee coverage does not cover for any commissioning or in site maintenance jobs or either products proved to have been tampered with or faulted by material wear and tear. In this regard, metal compensators are equipment subject to wear and tear and material fatigue, and thus, of limited life service. Life span will strongly depend on the working conditions such as frequency and number of cycles, movements range, pressure, temperature, medium, flow velocity, turbulence, water hammer, environmental aggression, etc. Likewise, an undue installation could even lead to equipment failure even before start-up.

The Purchaser is responsible for checking that the in-coming product is received in good condition and conforms to the ordered specifications. In case of damage caused during transit it is necessary to immediately complain to the carrier within 24 hours. After this time carriers could not assume the derived costs.

3. – ESSENTIAL SAFETY GUIDELINES

- Read this manual before installing the product.
- Always use the product within the scope of intended service and operating duties.
- Essential safety working regulations are to be strictly kept.
- Only qualified personnel should start up and regularly follow maintenance jobs at the plant.
- Any deviation from the usual installation guidelines should be notified to us for recommendation and approval.

4. – PRESERVATION, STORAGE & TRANSPORTATION

- Keep storage protection. Always use right handling means and proper packing for transportation.
- Avoid extreme temperatures, high environmental humidity or corrosive environment. Keep the valves away from dust, rain or flames to minimize damage and rust of the valve surface.
- Some steel parts are prime coated by a paint layer against corrosion during transport & storage, do not damage this layer.
- Avoid bumping or external vibrations. Do not pile up excessive weight. In case of severe bumping inspect the material for any damage and replace if necessary.

5. – INSTALLATION

Bear in mind the following guidelines along with general installation practice:

- Check the equipment design codes in relation with the applicable plant codes.
- Ensure that pressure design, temperature design, construction materials compatibility and other essential parameters conform with the duty. (Check operating limits on the Data Sheets)
- Consider the interaction between the system and the equipment. Proper selection and location of the compensators, as well as proper guiding and anchoring of the system are essential for the safe and proper use of the compensator, as explained in detail here below.
- The system should be designed in such a way to avoid high velocities, pulsing flow or water hammers, which are very harmful for compensators and the rest of the components.
- Allow enough space for installation and maintenance operations.

Reaction forces. Anchoring and Guiding. Limit Rods

REACTION FORCES

- Reaction force by internal pressure:

Metal compensators are flexible components which break the pipe system rigidity. A compensator acts as a piston by the forces arising from the internal pressure of the pipe. To prevent the pipes from damage they have to be properly anchored in order to absorb these reaction forces (Fr).

The reaction force caused by internal pressure in a compensator is calculated by the following formula:

$$Fr (N) = P (kg/cm^2) \times A (cm^2) \times 10$$

Fr = Reaction Force caused by internal pressure

P = Internal pressure

(Max. Working Pressure and Testing Pressure must be considered)

A = Effective cross sectional area (given in our Data Sheets)

This reaction force can be absorbed by limit rods provided as standard for S50 compensators.

The rest of reaction forces to be absorbed by system anchors are as follows:

- Reaction forces caused by the innate compensator resistance to move, calculated through the compensator stiffness, normally given in N/mm (linear).
- Reaction forces caused by the friction of the guides.
- Reaction forces by the weight of the system not hold by the Guides.
- Centrifugal forces on bends caused by flow velocity.

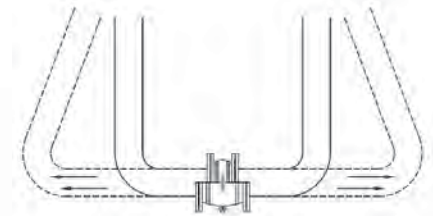

Compensator under pressure acts as a piston. Results shown when working without anchoring

ANCHORING. FIX POINTS

We call Fix Points to the anchors that hold the pipe and absorb reaction forces.

Every compensator has to be installed between two Fix Points.

Intermediate Fix Points are the ones just absorbing forces caused by compensator stiffness and friction of Guides, whereas Main Fix Points also absorb the forces caused by internal pressure, centrifugal forces and system weight not supported by Guides.

Main Fix Points are normally located in pump groups, valves, bends, crosses, line ending or flow change sections of the pipe work.

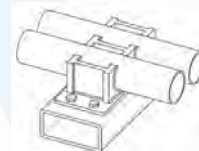

Fix point welded for pipes in parallel



Fixed point for elbow

GUIDING

Guides not only support the pipe system weight, but also maintain correct alignment so that the compensators work adequately. It is important to notice that Guides supporting the pipe system are not Fixed points.

The Guides should be positioned according to certain rules given further on and they prevent buckling of the line.

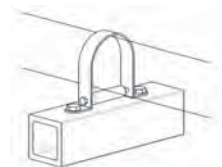

Guide with roller stand

LIMIT RODS

Their purpose is to absorb the force caused by internal pressure, and release Fix Points from this reaction force. Fix Points are still necessary to hold the pipe and absorb the remaining reaction forces.

Limit rods can help to control compensator presetting, as well as bellow over-extension and/or over-compression. S50 compensators have limit rods as standard.

Installation Guidelines for compensators working to balance thermal axial expansion/contraction

Selection of compensators and positioning of Fix Points and Guides in a pipeline must be studied at the same time.

We recommend dividing the complete system into simple configurations. The whole selection depends on the movements to be absorbed, pipe system lay out, availability for setting Fix Points and Guides, and compensator type to be used.

As above explained we have to differentiate between the Main and Intermediate Fix Points. Reaction forces to be absorbed by anchors have to be calculated and assigned to the Fix Points for their correct design.

Since S25 compensators do not have Limit Rods, Fix Points must be sized to also absorb the total reaction force caused by internal pressure.

Calculation of movements to be absorbed by the compensator

A pipe undergoes and increases in dimensions when its temperature changes. To calculate the change in length in a pipeline it is necessary to know what the temperature differential will be, the expansion coefficient of the pipe and the length of the pipe to be protected by the compensator. Maximum movements allowed for each compensator type are stated in our Data Sheets.

- Establishing the building installation length. When all or most of the movement is in one direction, the compensator can be installed with building length favouring the absorption in such direction. This can reduce the number of compensators needed and thus the number of anchors and guides. Allowed building length range for each compensator type is stated in our Data Sheets. Whatever the case, it must be taken into account that working close to the limit length reduces compensator life.

Herewith some examples and recommendations for compensators location with proper anchoring and guiding, when balancing thermal changes in a pipe work.

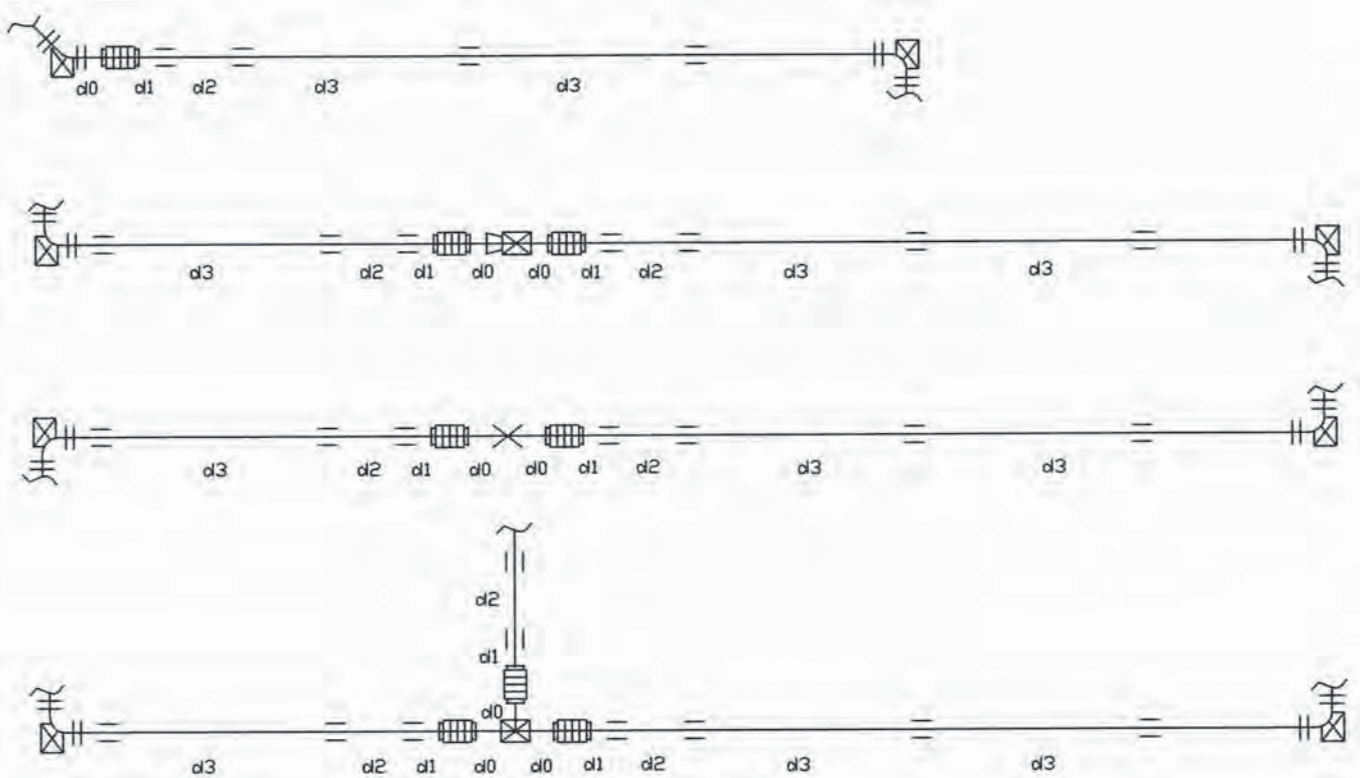

<p>Symbol.</p> <p> Compensador de dilatación / Expansion Joint</p> <p> Punto Fijo Principal / Main Fixed Point</p> <p> Punto Fijo Intermedio / Intermediate Fixed Point</p>		<p> Guía tubular / Guide</p> <p> Codo / Elbow</p> <p> Cambio de sección tubería / Section change</p>		<p>Distancias recomendadas / Recommended Lengths</p> <p>d0 <= 4 x DN (mm) ó 300 mm (el de menor longitud/whichever is the less)</p> <p>d1 <= 4 x DN</p> <p>d2 <= 14 x DN (mm)</p> <p>d3 <= 400 / DN² (mm)</p>
---	--	--	--	--

Anchoring, guiding and location for compensators working to balance thermal axial expansion/contraction

Installation Guidelines for compensators working to absorb vibrations

A compensator should work either as expansion compensator or to absorb vibrations, but not both functions at the same time; installation, pipe anchoring and guiding requirements are different.

Standard compensators S25 and S50 have a certain capacity to absorb low amplitude vibrations, but they are not design for such purpose. TORAFLEX® offers specific configurations for such purpose without internal sleeve.

The compensator must be installed in its rest position, near the source of vibrations (pump, compressor, etc.), leaving just 1-1,5 DN distance, or more in case the compensator could be affected by direct flow stream. The equipment source of vibrations must be properly anchored to absorb reaction forces and another Fix Point must be set immediately after the compensator to limit the vibrations amplitude onto the pipe. Proper guiding of the pipe work is also necessary to ensure the compensator works correctly.

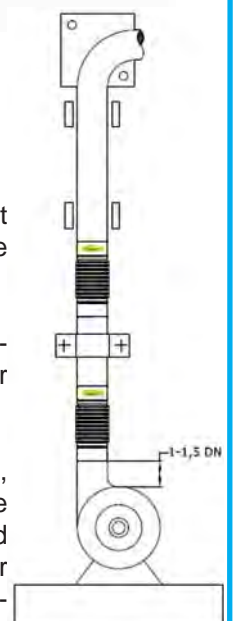

Installation of compensators to absorb vibrations

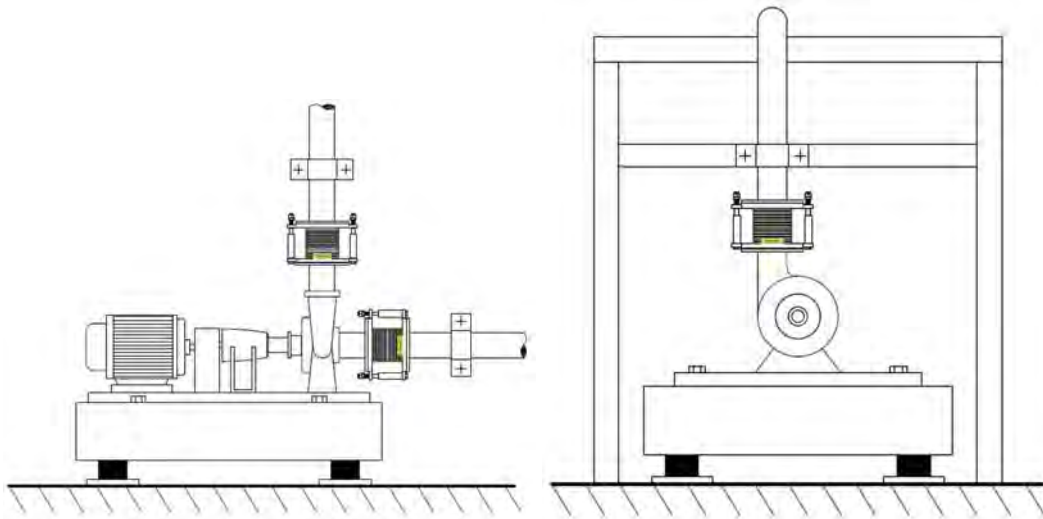

Installation of compensators working to absorb vibrations

Assembling the compensator to the pipe

- Remove the remaining storage protection.
- Ensure that compensator and piping work are completely free from dirt, rust, pipe, scale, welding slag or any other foreign material. In case of use of cleaning products, make sure they are compatible with materials of construction.
- Start installation only once all work on the adjacent pipe (flanges welding, anchors setting, etc.) has been completed and cooled down.
- Make sure the free space for the compensator is according to the expected movements to be absorbed, taking into account the pipe temperature at installation time. Compensators with anti-vibratory function to be installed in their rest position.

Installation position

Metal compensators are unidirectional, with flow direction according to arrow on the equipment, and can be installed either in horizontal or vertical pipelines.

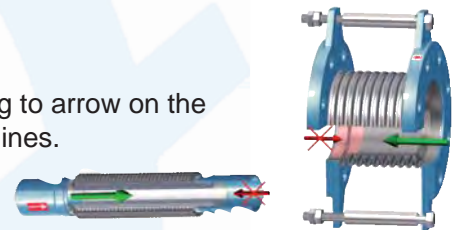

Installation of S50 compensators (flanged ends)

- Make sure that counter-flanges are compatible with standard of compensator flanges.
- Ensure that contact faces of compensator flanges and counter-flanges are free of dirt and in good condition.
- Check correct pipe alignment, anchoring and guiding, in accordance to the recommendations of this manual. Counter-flanges should fit smoothly. Avoid gradients, rotation and pipe misalignment that could cause pipe and valve stress and leakage once installed.
- Select the proper flange face gaskets according to duty and centre them on the flange face properly.
- Do not force the counter-flanges and do not try to tighten the bolts when a gap exists between valve and pipe or if misalignment is observed. Tighten in a crosswise, moderate and uniform manner. During start-up tighten again if leakage is noticed or replace gasket if necessary.

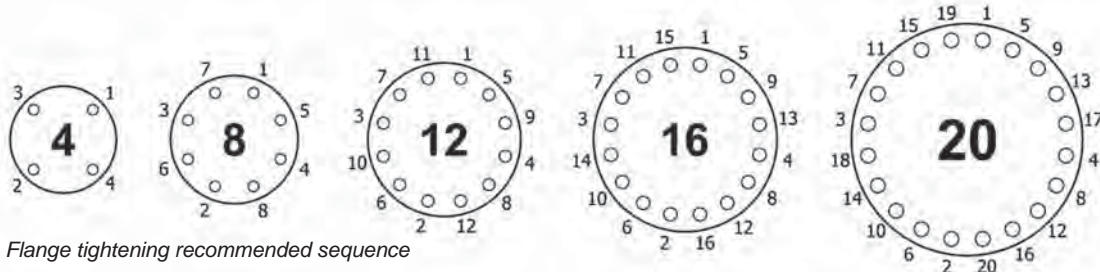

Flange tightening recommended sequence

Installation of S25 compensators (butt weld ends)

- Ensure that compensator and pipe ends are compatible dimension and material wise.
- Clean carefully compensator and pipe ends.
- Check correct pipe alignment, anchoring and guiding, in accordance with recommendations of this manual.
- Use a suitable electrode in accordance to compensator and pipe ends materials.
- Welding to be carried out by qualified personnel, controlling the source of heat to prevent bellows damage.

6. – START-UP & OPERATION

- Re-check all the issues raised in previous chapter "Installation".
- Make sure that all guides and anchors are firmly secured in their right place and working properly before and during first load.
- Filling, warming-up and starting-up shall be gradual so as to avoid any inadmissible stress and risk of accident.
- Inspect guides to discard jamming and anchors resistance.
- Check for tightness at compensator/pipe connections. Retighten flange union bolts/nuts crosswise and gradually if necessary until leakage elimination. If leakage persists, correct alignment and centring of the equipment should be checked, surfaces should be thoroughly cleaned and gaskets changed. If contact surfaces are irreversibly damaged replace them.
- Maximum recommended hydraulic test pressure $1,5 \times PN$, with water at ambient temperature. Anchoring should be properly sized to bear with test pressure.

Warning! Temperatures above 50°C or below 0°C may cause personnel injuries if compensators are touched. Ensure that the corresponding warning signs are displayed on the valve or surrounding area, or isolate the equipment in case of danger.

7. – MAINTENANCE AND REGULAR CHECKING

Maintenance and corresponding intervals between them should be defined and scheduled by the plant operation personnel according to service level.

As explained in previous chapters, metal compensators are equipment subject to wear and tear and material fatigue, and thus, of limited life service. Life span will strongly depend on the working conditions such as frequency and number of cycles, movements range, pressure, temperature, medium, flow velocity, turbulence, water hammer, environmental aggression or proper installation.

Wait for the valve medium to cool down before starting any maintenance work at the plant, release the pressure from the system, drain the line and pipe system in the event of toxic, corrosive, flammable or caustic fluids.

- Check that compensator is working properly without jamming or damage of mechanical components (bellow, tie rods). Check that there is no dust or other deposits compromising the proper functioning of the equipment.
- Check that anchoring and guiding of the pipe work are in good condition.
- Check the compensator surface inside and outside. If advanced corrosion or erosion is observed, double check service and compensator features and replace it properly.
- In case of advanced wear and tear is observed, we recommend to replace the equipment as a preventive measure.
- If there is leakage through unions, refer to Chapter "Start-Up".
- If there is leakage through the body, double check service, correct installation and compensator features and replace the equipment immediately.

Full technical support available through our website www.comeval.es or your local distributor.

