

# Needle valve

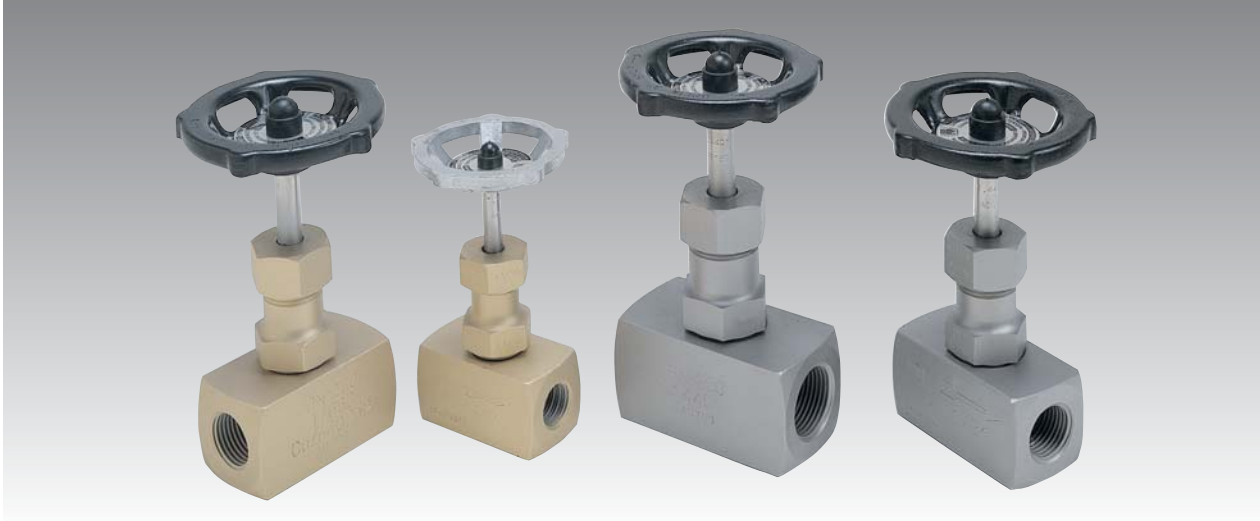

Model 147



For liquids, gases and steam.  
For use in hydraulic, pneumatic, heating and steam systems, chemical and food industries, etc.

In accordance with the requirements of directive 97/23/EC.

EC valve verification certified by: TÜV Internacional Grupo TÜV Rheinland, S.L. EC 1027.

Final product verification EC examination (Module A1) certified by: TÜV Internacional Grupo TÜV Rheinland, S.L.  
In compliance with the ATEX 94/9/CE directive "Protective equipment and systems for use in potentially explosive atmospheres".

In stainless steel with compliance with the NACE MR0175/EN ISO 15156:2003, "Petroleum and natural gas industries -Materials for use in H2S- containing environments in oil and gas production".

## Specifications

- Mobile or floating closure.
- Reduced pitch.
- Lightly tightening the handwheel guarantees it is perfectly tightness, which exceeds the standard DIN-3230. Sheet 3.
- Axis with rear closure "back seating" which allows the packing to be changed while in use and thus avoids it having any contact with the fluid.
- Fully constructed from laminated bars.

## IMPORTANT

Depending on demand:

- Possibility of manufacture in other types of material, for use in special working conditions (high temperatures, fluids, etc.).
- PTFE (Teflón) packing.
- Stainless steel handwheel or handle (EN-1.4401).
- Other connections.

Nº. PIECE	PIECE	MATERIAL										
		BRASS		CARBON STEEL		STAINLESS STEEL						
1	Body	Brass (EN-CW617N)		Carbon steel (EN-1.1191)		Stainless steel (EN-1.4401)						
2	Closure	Stainless steel (EN-1.4401)		Stainless steel (EN-1.4401)		Stainless steel (EN-1.4401)						
3	Stuffing box body	Brass (EN-CW617N)		Carbon steel (EN-1.1191)		Stainless steel (EN-1.4401)						
4	Ring	Stainless steel (EN-1.4401)		Stainless steel (EN-1.4401)		Stainless steel (EN-1.4401)						
5	Packing	Graphite		Graphite		Graphite						
6	Stuffing box	Brass (EN-CW617N)		Carbon steel (EN-1.1191)		Stainless steel (EN-1.4401)						
7	Stuffing box nut	Brass (EN-CW617N)		Carbon steel (EN-1.1191)		Stainless steel (EN-1.4401)						
8	Axis	Stainless steel (EN-1.4401)		Stainless steel (EN-1.4401)		Stainless steel (EN-1.4401)						
9	Handwheel (1)	Carbon steel (EN-1.0517)		Carbon steel (EN-1.0517)		Carbon steel (EN-1.0517)						
10	Plate	Aluminium		Aluminium		Aluminium						
11	Nut	Stainless steel (EN-1.4401)		Stainless steel (EN-1.4401)		Stainless steel (EN-1.4401)						
12	Washer	Stainless steel (EN-1.4401)		Stainless steel (EN-1.4401)		Stainless steel (EN-1.4401)						
DN		1/4" a 2" (GAS, NPT or SW)										
PN		200		250		250						
OPERATING CONDITIONS	PRESSURE IN bar	200	175	34	250	211	180	167	250	207	170	164
	MAXIMUM TEMP. IN °C	120	150	200	120	300	350	400	120	200	350	400
	MINIMUM TEMP. IN °C	- 60			- 10			- 60				

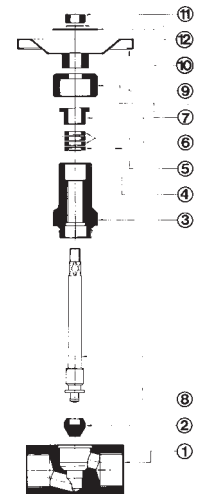

(1) The 1/4" to 1 1/4" handwheels are supplied in Aluminium (EN-AC-44200).

R		1/4"	3/8"	1/2"	3/4"	1"	1 1/4"	1 1/2"	2"	
CONNECTIONS		Whitworth gas-tight cylindrical female thread ISO 228/1 1978 (DIN-259)								
		NPT thread ANSI - B 2.1								
		Socket welding ends SW ANSI - B 16.11								
H		77	89	102	111	132	158	172	191	
H <sup>1</sup>		83	94	111	121	146	173	192	216	
L		50	55	65	75	90	95	100	112	
D		60	60	75	75	90	100	125	125	
REDUCED PITCH Ø		6,00	8,00	9,50	11,50	15,00	17,00	21,00	25,00	
WEIGHT IN Kgs.	BRASS	0,38	0,65	0,98	1,12	2,58	3,36	4,59	7,76	
	CARBON STEEL	0,35	0,50	0,92	1,05	2,40	3,16	4,31	7,22	
	STAINLESS STEEL	0,36	0,51	0,93	1,06	2,43	3,20	4,36	7,31	
CODE	BRASS 2004-147.	GAS	0041	0381	0021	0341	0101	0141	0121	0201
		NTP	00411	03811	00211	03411	01011	01411	01211	02011
	CARBON STEEL 2004-147.	GAS	0044	0384	0024	0344	0104	0144	0124	0204
		NTP	00441	03841	00241	03441	01041	01441	01241	02041
		SW	00442	03842	00242	03442	01042	01442	01242	02042
	STAINLESS STEEL 2004-147.	GAS	0042	0382	0022	0342	0102	0142	0122	0202
		NTP	00421	03821	00221	03421	01021	01421	01221	02021
		SW	00422	03822	00222	03422	01022	01422	01222	02022

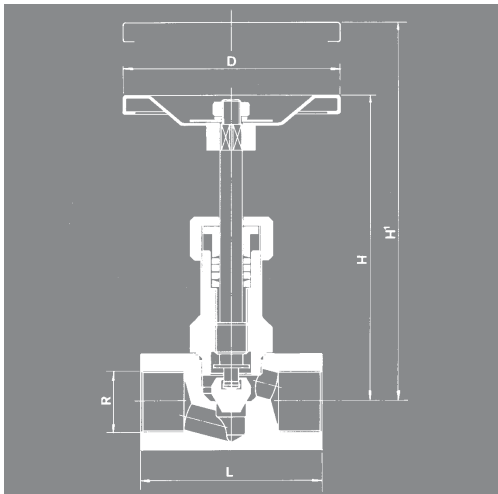

DN	FLOW COEFFICIENT	
	Kv m <sup>3</sup> /h ΔP = 1 bar	Cv l/min. ΔP = 1 Psi = 0,07 bar
1/4"	0,68	3,00
3/8"	1,11	5,00
1/2"	2,16	10,10
3/4"	4,10	18,80
1"	6,20	25,00
1 1/4"	9,80	43,00
1 1/2"	12,95	52,00
2"	19,40	82,00

### Load losses

The adjoining diagram reflects the load loss curves for water at 20°C.

In order to determine other fluids load losses, calculate the flow of these equivalent to water.

$$Q_A = \sqrt{\frac{\rho}{1.000}} \cdot Q$$

Q<sub>A</sub> = Flow equivalent to water in m<sup>3</sup>/h.

ρ = Fluid density in operating conditions in Kg/m<sup>3</sup>.

Q = Fluid flow in operating conditions in m<sup>3</sup>/h.

