

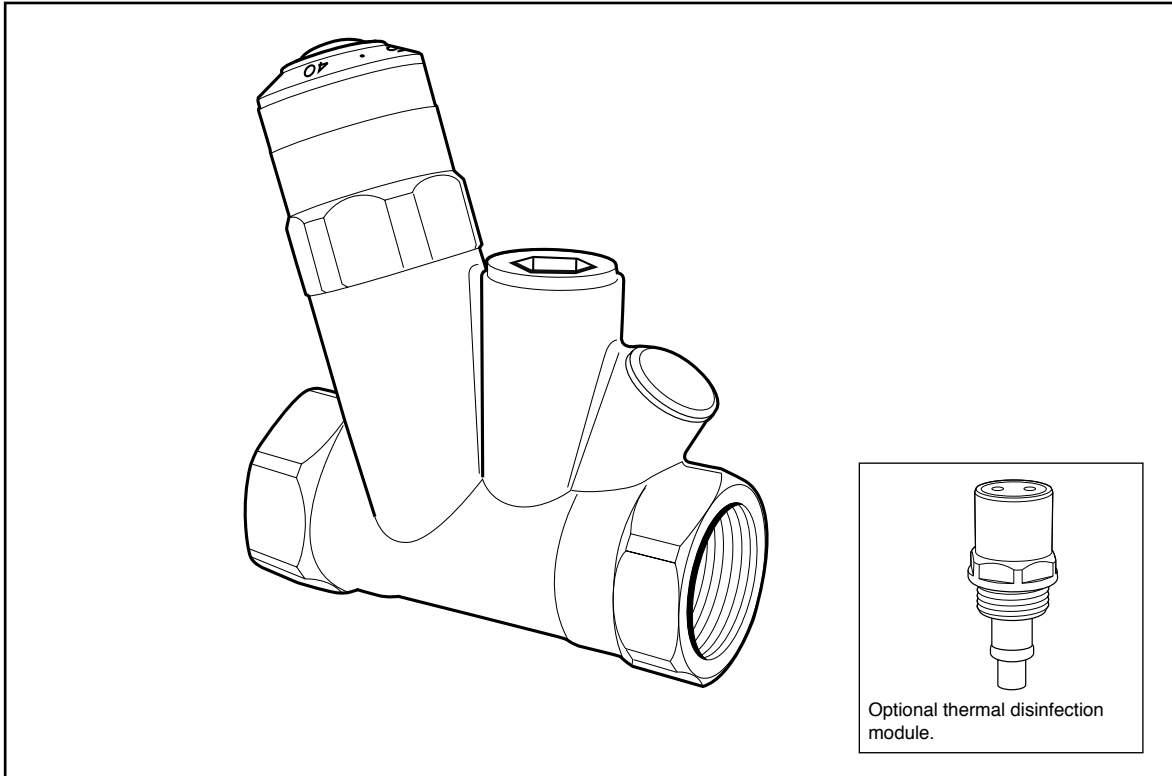

Product Specification Sheet

Thermal Balancing Valve



Valve for thermostatic regulation within a hot water circulation system.

Product Features and Benefits

- Supplied with female connections for **easy adaptation to a wide range of fitting requirements.**
- **Cartridge construction for fast, easy maintenance.**
- **Compact design to make installation as easy as possible.**
- **Easy, tamperproof set up** within the adjustable range of 35 to 60°C.
- **Optional thermal disinfection module allows automatic disinfection function at 68°C to kill legionella in the system.**
- Temperature gauge connection point.
- Range of accessories and spares available.

Thermal Balancing Valve

Description

A tamperproof multi function thermostatic balancing valve for use in domestic hot water circulation systems.

The valve provides a thermal balance in hot water installations by keeping a constant temperature in the system, thus limiting the flow in the circulation pipes to the minimum required level. The optional thermal disinfection module allows automatic thermal disinfection at temperatures above 68°C with safety protection of the installation to prevent the temperature rising above 75°C by automatically shutting off the circulation flow.

Product Range

TREG 100 050: 1/2" FBSP Thermal Balancing Valve

TREG 100 055: 3/4" FBSP Thermal Balancing Valve

ACCESSORIES

AREG 100 001: Thermal Disinfection Module

AREG 100 005: Thermometer with Adaptor

AREG 100 010: 1/2" MBSP Nipples c/w Isolating Valve

AREG 100 015: 3/4" MBSP Nipples c/w Isolating Valve

Installation

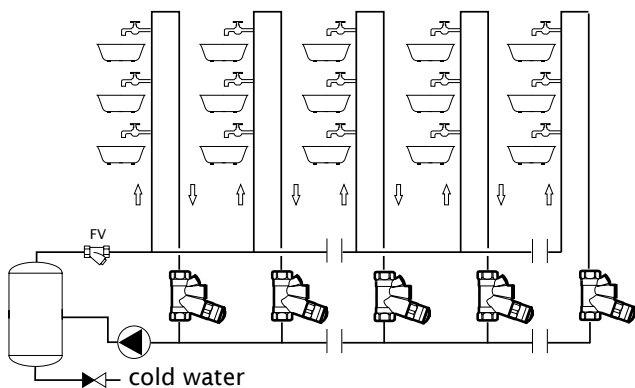

Performance

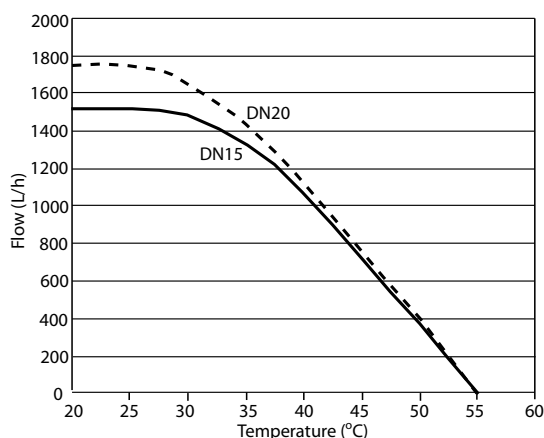

Dimensions

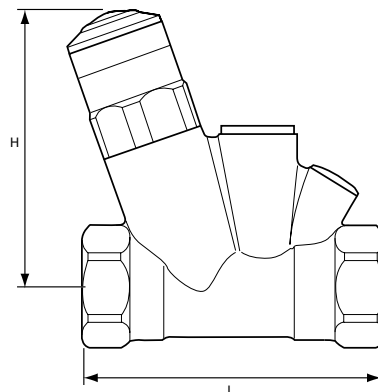

Size	H	L
1/2"	79	75
3/4"	92	80

All dimensions in mm unless stated

Specifications

Maximum static pressure: 16 bar

Maximum working pressure: 10 bar

Maximum flow temperature: 100°C

Materials

Valve body: DZR Brass

O-Rings: EPDM Rubber

Spring: Stainless steel

Cone: Stainless steel

How to Specify

Multi function valve with FBSP connections for use in hot water circulation systems, including drain point, temperature gauge point and automatic thermal disinfection function (include correct product range code).

Guarantee

All Reliance® products undergo strict performance tests prior to despatch, and are guaranteed against faulty materials and workmanship for one year from the date of purchase. This is in addition to any statutory rights.

Contacts:	Sales Enquiries	Technical Support
Telephone:	+44 (0)1386 712400	+44 (0)1386 47148
Fax:	+44 (0)1386 47028	+44 (0)1386 422217
E-Mail:	sales@rwc.co.uk	technical@rwc.co.uk



Reliance Water Controls®
 Worcester Road, Evesham, Worcestershire, WR11 4RA, UK
 Tel: +44 (0)1386 47148 Fax: +44 (0)1386 47028 www.rwc.co.uk

