

Normal safety valve with spring loading. (AN)

Model 494

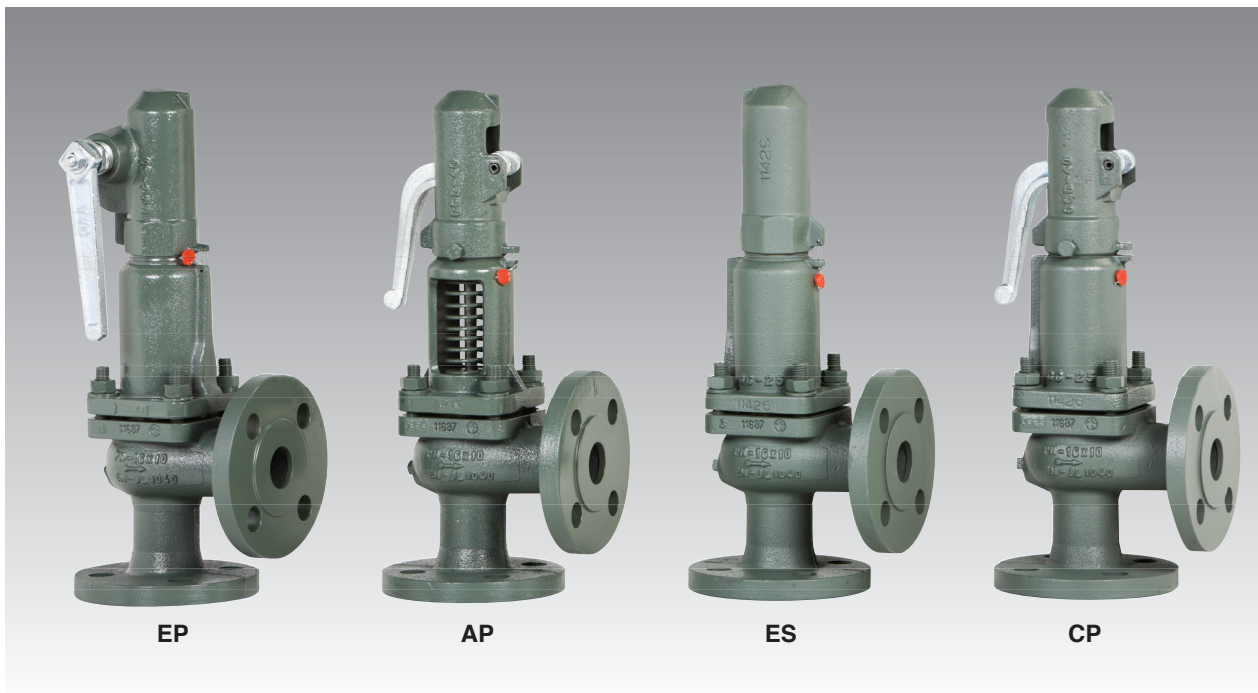

The valve works as an automatic pressure releasing regulator activated by the static pressure existing at the entrance to the valve and is characterized by its ability to open, at the first proportional to the pressure increase, and after instantly and totally.

Design in accordance with "International Standard ISO 4126-1:2004 Safety Valves".

In accordance with the requirements of directive 97/23/EC.

EC valve verification certified by: TÜV Internacional Grupo TÜV Rheinland, S.L. EC 1027.

Type (Module H/H1) EC examination report n° 0.04.03.05001 certified by: TÜV Internacional Grupo TÜV Rheinland, S.L.

In compliance with the ATEX 94/9/CE directive "Protective equipment and systems for use in potentially explosive atmospheres".

Other authorisations: ISCIR, ITI, NASTHOL,...etc.

Specifications

- 90° angular flow.
- Activated by direct action helicoid spring.
- Simplicity of construction ensuring minimum maintenance.
- Materials carefully selected for their resistance to corrosion. With the exception of washers and couplings, the valves are free of non-ferric materials.
- Internal body designed to offer favourable flow profile.
- Sealing surfaces treated and balanced, making them extremely tightness, even exceeding DIN-3230 requirements. Page 3.
- Great discharge capacity. For liquids typically used with openings similar to proportional safety valves.
- Equipped with draining screws for removing condensation.
- Auto-centering plug.
- Threaded shaft with lever positioner facilitating immediate manual action.
- Elevator, independent of the seal, designed facilitate sudden opening when the steam expands and, with any fluid, guarantees absolute opening and closing precision.
- All the valves are supplied sealed at the set pressure requested, simulating operational conditions, and are vigorously tested.
- All components are numbered, registered and checked. If requested in advance, material, casting, test and efficiency certificates will be enclosed with the valve, and the instruction manual, in accordance with P.E.D.97/23 EC.

IMPORTANT

Depending on demand:

- 1.- Blocking screw which facilitates hydrostatic testing of the container which to be protected.
- 2.- Rapid limiter to reduce the coefficient of discharge.
- 3.- Fluorelastomer (Vitón) seals, Silicone's rubber, PTFE (Teflón)... etc., achieving leakage levels less than $0,3 \times 10^{-3} \frac{\text{Pa} \cdot \text{cm}^3}{\text{seg.}}$

The ranges of application allow certain flexibility although we recommend limiting them to:

RANGE OF APPLICATION FOR THE SEALS							
FLUID	SET PRESSURE IN bar						
	0,2	1,8	4,0	4,8	7,0	30,0	40,0
Saturated steam	S	V			T		
Liquids and gases	S			V		T	
SEALS	TEMPERATURE IN °C						
		ACCORDING TO MANUFACTURERS		RECOMMENDED BY VYC			
		MINIMUM	MAXIMUM	MINIMUM	MAXIMUM		
Silicone's rubber	S	-60	+200	-50	+115		
Fluorelastomer (Vitón)	V	-40	+250	-30	+150		
PTFE (Teflón)	T	-265	+260	-80	+230 (1)		

(1) For temperatures exceeding 230°C apply metallic seal only

- 4.- Fluorelastomer (Vitón) membrane and O-ring isolating the rotating or sliding parts from the working fluid.
- 5.- Electrical contact indicating open/closed.
- 6.- Balance bellows to:
 - Protect the spring from atmospheric influences.
 - Ensure outside of valve body is totally tightness.
 - Level out external or self-generated back pressure.
- 7.- Possibility of manufacture in other types of material, for special operating conditions (high temperatures, fluids, etc.).
- 8.- Totally free of oil and grease, to work with oxygen, avoiding possible fire risks (UV-Oxygen-VBG 62).
- 9.- Special springs for critical temperatures.

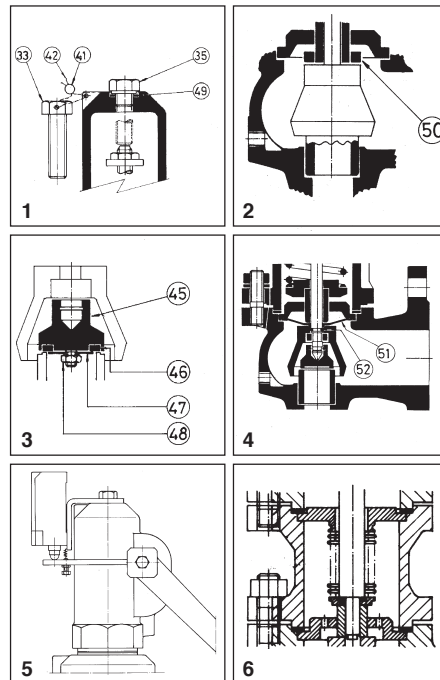

Nº. PIECE	PIECE	MATERIAL																			
		CAST IRON				NODULAR IRON				CAST STEEL				STAINLESS STEEL							
1	Body	Cast iron (EN-JL1040)				Nodular iron (EN-JS1030)				Cast steel (EN-1.0619+N)				Stainless steel (EN-1.4408)							
2	Closed bell	Cast iron (EN-JL1040)				Nodular iron (EN-JS1030)				Cast steel (EN-1.0619+N)				Stainless steel (EN-1.4408)							
3	Open bell	Cast iron (EN-JL1040)				Nodular iron (EN-JS1030)				Cast steel (EN-1.0619+N)				Stainless steel (EN-1.4408)							
4, 5, 6	Hood	Nodular iron (EN-JS1030)				Nodular iron (EN-JS1030)				Nodular iron (EN-JS1030)				Stainless steel (EN-1.4408)							
7	Elevator	Nodular iron (EN-JS1030) (1)				Nodular iron (EN-JS1030) (1)				Nodular iron (EN-JS1030) (1)				Stainless steel (EN-1.4408)							
8	Cam	Nodular iron (EN-JS1030) (1)				Nodular iron (EN-JS1030) (1)				Nodular iron (EN-JS1030) (1)				Stainless steel (EN-1.4408)							
9, 10	Lever	Nodular iron (EN-JS1030)				Nodular iron (EN-JS1030)				Nodular iron (EN-JS1030)				Nodular iron (EN-JS1030)							
11	Seating	Stainless steel (EN-1.4028)				Stainless steel (EN-1.4028)				Stainless steel (EN-1.4028)				Stainless steel (EN-1.4542)							
12	Plug	Stainless steel (EN-1.4028)				Stainless steel (EN-1.4028)				Stainless steel (EN-1.4028)				Stainless steel (EN-1.4542)							
13	Lead	Stainless steel (EN-1.4028)				Stainless steel (EN-1.4028)				Stainless steel (EN-1.4028)				Stainless steel (EN-1.4401)							
14	Spring press	Carbon steel (EN-1.1191)				Carbon steel (EN-1.1191)				Carbon steel (EN-1.1191)				Stainless steel (EN-1.4305)							
15	Separator	Stainless steel (EN-1.4028)				Stainless steel (EN-1.4028)				Stainless steel (EN-1.4028)				Stainless steel (EN-1.4401)							
16	Rod	Stainless steel (EN-1.4028)				Stainless steel (EN-1.4028)				Stainless steel (EN-1.4028)				Stainless steel (EN-1.4401)							
17	Lever shaft	Carbon steel (EN-1.1191)				Carbon steel (EN-1.1191)				Carbon steel (EN-1.1191)				Stainless steel (EN-1.4305)							
18	Gudgeon	Carbon steel (EN-1.1231)				Carbon steel (EN-1.1231)				Carbon steel (EN-1.1231)				Stainless steel (EN-1.4310)							
19	Ring	Stainless steel (EN-1.4028)				Stainless steel (EN-1.4028)				Stainless steel (EN-1.4028)				Stainless steel (EN-1.4401)							
20, 21	Safety ring	Stainless steel (EN-1.4310)				Stainless steel (EN-1.4310)				Stainless steel (EN-1.4310)				Stainless steel (EN-1.4310)							
22	Spring	Vanadium-chrome steel (EN-1.8159) (2)				Vanadium chrome steel (EN-1.8159) (2)				Vanadium chrome steel (EN-1.8159) (2)				Stainless steel (EN-1.4310) (3)							
23	Gland	Carbon steel (EN-1.1191)				Carbon steel (EN-1.1191)				Carbon steel (EN-1.1191)				Stainless steel (EN-1.4305)							
24	Hollow screw	Stainless steel (EN-1.4305)				Stainless steel (EN-1.4305)				Stainless steel (EN-1.4305)				Stainless steel (EN-1.4305)							
25	Hollow screw nut	Stainless steel (EN-1.4305)				Stainless steel (EN-1.4305)				Stainless steel (EN-1.4305)				Stainless steel (EN-1.4305)							
26	Buffer nut	Stainless steel (EN-1.4305)				Stainless steel (EN-1.4305)				Stainless steel (EN-1.4305)				Stainless steel (EN-1.4305)							
27	Rod check nut	Carbon steel (EN-1.1141)				Carbon steel (EN-1.1141)				Carbon steel (EN-1.1141)				Stainless steel (EN-1.4401)							
28, 29, 48	Nut	Carbon steel (EN-1.1141)				Carbon steel (EN-1.1141)				Carbon steel (EN-1.1141)				Stainless steel (EN-1.4401)							
30, 31	Washer	Carbon steel (EN-1.1141)				Carbon steel (EN-1.1141)				Carbon steel (EN-1.1141)				Stainless steel (EN-1.4401)							
32	Stud	Carbon steel (EN-1.1181)				Carbon steel (EN-1.1181)				Carbon steel (EN-1.1181)				Stainless steel (EN-1.4401)							
33, 34, 35	Screw	Carbon steel (EN-1.1191)				Carbon steel (EN-1.1191)				Carbon steel (EN-1.1191)				Stainless steel (EN-1.4401)							
36	Cap	Carbon steel (EN-1.1181)				Carbon steel (EN-1.1181)				Carbon steel (EN-1.1181)				Stainless steel (EN-1.4401)							
38	Coupling	Graphite				Graphite				Graphite				PTFE (Teflón)							
39	Coupling	PTFE (Teflón)				PTFE (Teflón)				PTFE (Teflón)				PTFE (Teflón)							
40	Seal	Graphite				Graphite				Graphite				PTFE (Teflón)							
41	Seal	Plastic				Plastic				Plastic				Plastic							
42	Sealing wire	Sealing wire				Sealing wire				Sealing wire				Sealing wire							
43	Characteristic plate	Stainless steel (EN-1.4301)				Stainless steel (EN-1.4301)				Stainless steel (EN-1.4301)				Stainless steel (EN-1.4301)							
45	Plug	Stainless steel (EN-1.4401)				Stainless steel (EN-1.4401)				Stainless steel (EN-1.4401)				Stainless steel (EN-1.4401)							
46	Sealing disk	PTFE (Teflón)				PTFE (Teflón)				PTFE (Teflón)				PTFE (Teflón)							
		Silicone's rubber				Silicone's rubber				Silicone's rubber				Silicone's rubber							
		Fluorelastomer (Vitón)				Fluorelastomer (Vitón)				Fluorelastomer (Vitón)				Fluorelastomer (Vitón)							
47	Washer	Stainless steel (EN-1.4401)				Stainless steel (EN-1.4401)				Stainless steel (EN-1.4401)				Stainless steel (EN-1.4401)							
49	Coupling	Copper				Copper				Copper				PTFE (Teflón)							
50	Limiter	Stainless steel (EN-1.4028)				Stainless steel (EN-1.4028)				Stainless steel (EN-1.4028)				Stainless steel (EN-1.4401)							
51	Membrane	Fluorelastomer (Vitón)				Fluorelastomer (Vitón)				Fluorelastomer (Vitón)				Fluorelastomer (Vitón)							
52	O-ring	Fluorelastomer (Vitón)				Fluorelastomer (Vitón)				Fluorelastomer (Vitón)				Fluorelastomer (Vitón)							
DN ₁ x DN ₂		25 x 25 a 200 x 200																			
PN		16				40				40				40							
OPERATING CONDITIONS	PRESSURE IN bar	16	13	13	13	40	35	32	28	24	40	35	32	28	24	21	20	40	34	32	29
	MAX. TEMP. IN °C	120	200	250	300	120	200	250	300	350	120	200	250	300	350	400	450	120	200	300	400
	MIN. TEMP. IN °C	-10				-10				-10				-60							

(1) DN-25 x 25 in stainless steel (EN-1.4408).

(2) Spring steel (EN-10270-1-SH) for wire spring Ø ≤ 10 mm. Maximum temperature EP, ES and CP 250°C / AP 400°C.

(3) Vanadium chrome steel (EN-1.8159) for wire spring Ø > 10 mm.

Normal safety valve with spring loading (AN) model 494 - AP and CP.

1. Disassembly and assembly.

1.1 Disassembly.

To replace the spring (22) or clean any of the internal components of the valve, proceed in the following manner:

A - Withdraw the clip (18), using a punching tool, until the lever (10) comes free.

B - Loosen the screws (34) and take the cap (6) off.

C - Holding the spindle (16) steady, loosen the hollow screw nut (25) and the hollow screw (24) until you note a releasing of the spring (22).

D - Mark on the spindle (16) the position of the spindle lock-nut (27) and the adjusting nut (26). Loosen them and remove them.

E - Unscrew the nuts (29) and remove them, together with the studs (32) and their washers (30).

F - Lift the cover (3) or (2) and you will have access to all of the components.

1.2 Assembly.

A - Place the safety-ring (20) on the spindle (16) and press it against the gasket (12).

B - In the spindle channel (16) connect the ring (19) and fix it to the security-ring (21). Introduce the elevator (7) into the upper part of the spindle (16) and press this against the previously described pieces.

C - Enter the guide (13), the separator (15), the spring-press (14), the spring (22), the spring-press (14) through the upper part of the spindle (16) and press this against the previously described pieces.

D - Replace the assembly (38) and the cover (3) or (2).

E - Place the washers (30) on the studs (32) and make up the nuts (29) diagonally, checking the correct alignment of the cover (3) or (2).

F - Adjust the firing pressure with the hollow screw (24) and fix the adjustment position with the hollow screw nut (25).

G - Turn the spindle lock-nut (27) and the adjusting nut (26) to the position marked (see 1.1.D) and make up against each other.

H - Introduce the cap (6) and tighten the screws (34).

I - Place the lever (10) and fix it with the fastener (18).

2. Adjusting the firing pressure.

A - Proceed according to points 1.1.A, 1.1.B, 1.1.C.

B - Proceed according to points 1.2.F, 1.2.H, 1.2.I.

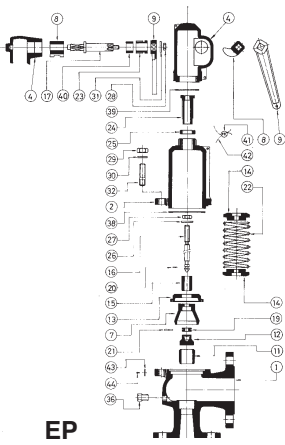

EP

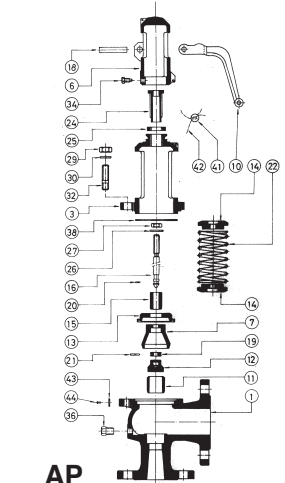

AP

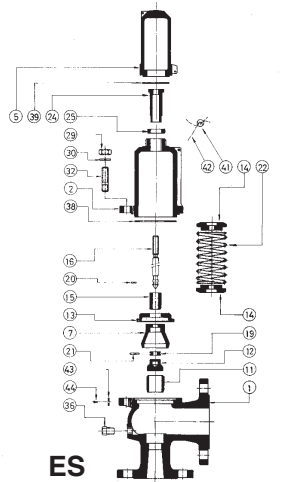

EP

Normal safety valve with spring loading (AN) model 494 - EP.

1. Disassembly and assembly .

1.1 Disassembly.

To replace the spring (22), or clean any of the internal components of the valve, proceed in the following manner:

A - Move the lever (9) in direction C as far as the constructive catcher.

B - Unscrew the cap (4) and remove.

C - Holding the spindle (16) steady, loosen the hollow screw nut (25) and the hollow screw (24) until you note a releasing of the spring (22).

D - Mark on the spindle (16) the position of the spindle lock-nut (27) and the adjusting nut (26). Loosen them and remove them.

E - Unscrew the nuts (29) and remove them, together with the studs (32) and their washers (30).

F - Lift the cover (2) and you will have access to all of the components.

1.2 Assembly.

A - Place the safety-ring (20) on the spindle (16) and press it against the gasket (12).

B - In the spindle channel (16) connect the ring (19) and fix it to the security-ring (21). Introduce the elevator (7) into the upper part of the spindle (16) and press this against the previously described pieces.

C - Enter the guide (13), the separator (15), the spring-press (14), the spring (22), the spring-press (14) through the upper part of the spindle (16) in a correlative manner.

D - Replace the assembly (38) and the cover (2).

E - Place the washers (30) on the studs (32) and make up the nuts (29) diagonally, checking the correct alignment of the cover (2).

F - Adjust the firing pressure with the hollow screw (24) and fix the adjustment position with the hollow screw nut (25).

G - Turn the spindle lock-nut (27) and the adjusting nut (26) to the position marked (see 1.1.D) and make up against each other.

H - Change the coupling (39) and lightly tighten the cap (4). Move the lever (9) towards position A as far as the constructive catcher. Definitely tighten the cap (4).

2. Adjustig the firing pressure.

A - Proceed according to points 1.1.A, 1.1.B, 1.1.C.

B - Proceed according to points 1.2.F, 1.2.H.

Normal safety valve with spring loading (AN) model 494 - ES.

1. Disassembly and assembly.

1.1 Disassembly.

To replace the spring (22), or clean any of the internal components of the valve, proceed in the following manner:

A - Unscrew the cap (5) and remove.

B - Holding the spindle (16) steady, loosen the hollow screw nut (25) and the hollow screw (24) until you note a releasing of the spring (22).

C - Unscrew the nuts (29) and remove them, together with the studs (32) and their washers (30).

F - Lift the cover (2) and you will have access to all of the components.

1.2 Assembly.

A - Place the safety-ring (20) on the spindle (16) and press it against the gasket (12).

B - In the spindle channel (16) connect the ring (19) and fix it to the security-ring (21).

Introduce the elevator (7) into the upper part of the spindle (16) and press this against the previously described pieces.

C - Enter the guide (13), the separator (15), the spring-press (14), the spring (22), the spring-press (14) through the upper part of the spindle (16) in a correlative manner.

D - Replace the washers (38) and the cover (2).

E - Place the washers (30) on the studs (32) and make up the nuts (29) diagonally, checking the correct alignment of the cover (2).

F - Adjust the firing pressure with the hollow screw (24) and fix the adjustment position with the hollow screw nut (25).

G - Change the coupling (39) and tighten the cap (5).

2. Adjusting the firing pressure.

A - Proceed according to points 1.1.A, 1.1.B.

B - Proceed according to points 1.2.F, 1.2.G.

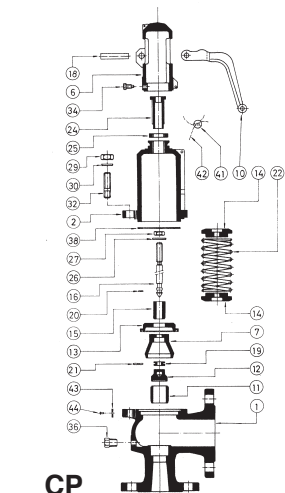

CP

DN ₁ x DN ₂	25 x 25	32 x 32	40 x 40	50 x 50	65 x 65	80 x 80	100 x 100	125 x 125	150 x 150	200 x 200
d ₀	16	20	25	32	40	50	63	77	93	110
A ₀ = $\frac{\pi \cdot d_0^2}{4}$	201	314	491	804	1257	1964	3117	4657	6793	9503
H	350	390	420	495	550	655	705	810	850	990
h ¹	112	129	129	148	148	191	191	191	191	223
L ₁	100	105	115	125	145	155	175	200	225	225
L ₂	100	105	115	125	145	155	175	200	225	250
R	1/4"	1/4"	1/4"	1/4"	3/8"	3/8"	3/8"	1/2"	1/2"	1/2"
Whitworth gas-tight cylindrical female thread ISO 228/1 1978 (DIN-259)										

INTAKE FLANGE	PN-10/16 EN-1092-2 (2) PN-25/40 EN-1092-1 (3)	D ₁	115	140	150	165	185	200	220	250	285	340	
		K ₁	85	100	110	125	145	160	180	210	240	295	
		I ₁	14	19	19	19	19	19	19	19	19	23	23
		b ₁	16	18	18	20	20	22	24	26	26	26	26
		DRILLS N.°	4	4	4	4	4	8	8	8	8	8	8
ESCAPE FLANGE	PN-10/16 EN-1092-2 (1) PN-25/40 EN-1092-1 (3)	D ₂	115	140	150	165	185	200	220	250	285	340	
		K ₂	85	100	110	125	145	160	180	210	240	295	
		I ₂	14	19(18)*	19(18)*	19(18)*	19(18)*	19(18)*	19(18)*	19(18)*	19(18)*	23(22)*	23(22)*
		b ₂	16	18	18	20	20(18)*	22(20)**	24(22)*(20)*	26(22)**	26(24)*(22)*	26(24)**	26(24)**
		DRILLS N.°	4	4	4	4	4	8	8	8	8	8	8

(1) From DN-200x200 PN-10.
(2) DN-200x200 PN-10.
(3) DN-200x200 PN-25.

MODEL	EP	AP	ES	CP	EP	AP	ES	CP	EP	AP	ES	CP	EP	AP	ES	CP	EP	AP	ES	CP	EP	AP	ES	CP	EP	AP	ES	CP	EP	AP	ES	CP								
CAST IRON	8,00	7,40	7,60	7,80	9,60	8,88	9,12	9,38	13,87	12,82	13,17	13,43	20,27	18,74	19,25	19,68	26,68	24,67	25,34	25,77	39,48	36,52	37,50	38,10	55,48	51,32	52,70	53,30	82,15	75,98	78,04	78,64	94,50	88,64	92,80	93,33	138,10	130,80	135,10	136,37
NODULAR IRON	8,73	8,07	8,29	8,49	10,47	9,68	9,94	10,20	15,13	13,99	14,37	14,63	22,11	20,45	21,00	21,43	29,11	26,92	27,65	28,08	43,08	39,84	40,92	41,52	60,54	55,99	57,51	58,11	89,64	82,91	85,15	85,75	97,00	91,16	95,39	95,84	173,48	162,25	170,43	171,80
CAST STEEL STAINLESS STEEL	8,50	7,86	8,07	8,27	10,60	9,80	10,07	10,33	14,87	13,75	14,12	14,38	21,27	19,67	20,20	20,63	28,68	26,52	27,24	27,67	41,48	38,36	39,40	40,00	58,48	54,09	55,55	56,15	87,15	80,61	82,79	83,39	104,38	97,86	102,65	103,10	152,10	144,48	149,30	150,63
CAST IRON 2002-494	5106	5106	5106	5106	5146	5146	5146	5146	5126	5126	5126	5126	5206	5206	5206	5206	5226	5226	5226	5226	5306	5306	5306	5306	5406	5406	5406	5406	5506	5506	5506	5506	5606	5606	5606	5606	5806	5806	5806	5806
NODULAR IRON 2002-494	8106	8106	8106	8106	8146	8146	8146	8146	8126	8126	8126	8126	8206	8206	8206	8206	8226	8226	8226	8226	8306	8306	8306	8306	8406	8406	8406	8406	8506	8506	8506	8506	8606	8606	8606	8606	8806	8806	8806	8806
CAST STEEL 2002-494	8104	8104	8104	8104	8144	8144	8144	8144	8124	8124	8124	8124	8204	8204	8204	8204	8224	8224	8224	8224	8304	8304	8304	8304	8404	8404	8404	8404	8504	8504	8504	8504	8604	8604	8604	8604	8804	8804	8804	8804
STAINLESS STEEL 2002-494	8102	8102	8102	8102	8142	8142	8142	8142	8122	8122	8122	8122	8202	8202	8202	8202	8222	8222	8222	8222	8302	8302	8302	8302	8402	8402	8402	8402	8502	8502	8502	8502	8602	8602	8602	8602	8802	8802	8802	8802

* Cast steel (EN-1.0619) and Stainless steel (EN-1.4408).
• Nodular iron (EN-JS1030).

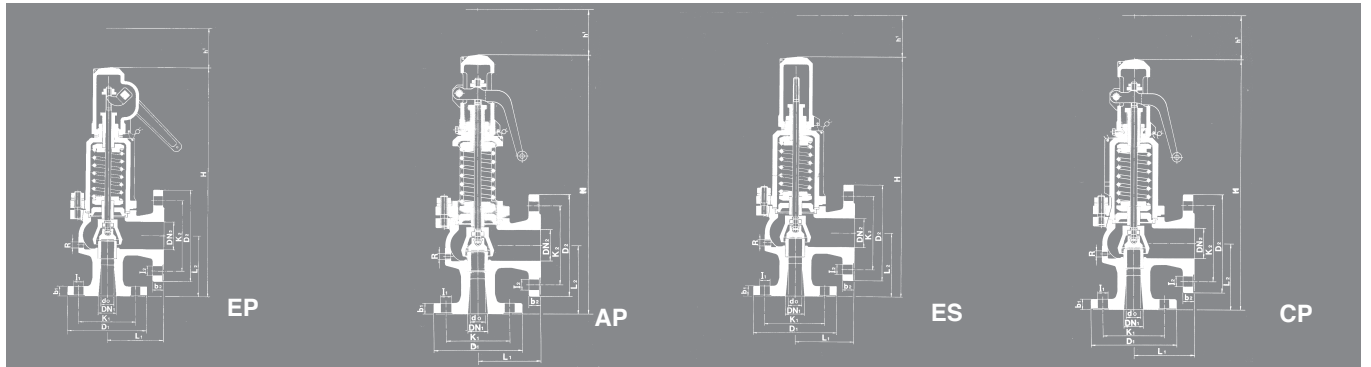

RECOMMENDED RANGES OF APPLICATION					
MODEL		EP	AP ⁽¹⁾	ES	CP ⁽¹⁾
FLUID	SATURATED STEAM	*	*		*
	GASES	*		*	
	LIQUIDS	*		*	
PERMISSIBLE BACK PRESSURE IN % OF SET PRESSURE	INTERNAL OR GENERATED	SATURATED STEAM GASES	15		
		LIQUIDS	—		
	EXTERNAL VARIABLE (1)	SATURATED STEAM GASES	—		
		LIQUIDS	—		
	EXTERNAL CONSTANT (1)(2)(3)	SATURATED STEAM GASES	50		
		LIQUIDS	90		
% OVERPRESSURE	SATURATED STEAM GASES	10			
	LIQUIDS	25			

OPEN AND CLOSED PRESSURES IN % OF SET PRESSURE			
FLUID	PRESSURE IN bar	OPENING PRESSURE	CLOSING PRESSURE
SATURATED STEAM GASES	< 3	+ 10 %	- 0,3 bar
	≥ 3	+ 10 %	- 10 %
LIQUIDS	< 3	+ 10 %	- 0,6 bar
	≥ 3	+ 10 %	- 20 %

- (1) If external overpressure exists, the AP and CP model cannot be used.
- (2) With external constant overpressure, the spring is adjusted deducting the overpressure from the set pressure.
- (3) If the set pressure < 3 bar we must consider the total atmospheric pressure (1 bar) as external constant overpressure being freely released.

If $p_a > 0,25p$, we must limit plug speed with the consequent reduction of the αd coefficient of discharge.
With the new reduced coefficient we determine the d_0 , in order to remove the necessary volume.

p_a = Overpressure permitted [bar] absolute.
 p = Set pressure [bar] absolute.
 αd = Coefficient of discharge.

SET PRESSURES AND REGULATING RANGES

DN ₁ x DN ₂		25 x 25	32 x 32	40 x 40	50 x 50	65 x 65	80 x 80	100 x 100	125 x 125	150 x 150	200x200	
SET PRESSURES IN bar	MAXIMUM (LIQUIDS AND GASES)	PN-16	16	16	16	16	16	16	16	12,5	10	
		PN-40	40	40	40	32	32	32	25	20	12,5	10
	MAXIMUM (SATURATED STEAM)	PN-16	13	13	13	13	13	13	13	13	12,5	10
		PN-40	32	32	30	24	22	24	20	18	12,5	10
	MINIMUM	STEAM AND GASES	0,5	0,5	0,5	0,5	0,5	0,5	0,5	0,5	0,5	0,5
		LIQUIDS	0,2	0,2	0,2	0,2	0,2	0,2	0,2	0,2	0,2	0,2
SPRING REGULATING RANGE IN bar	0,20 a 0,68	CODE	56210 56390	56226 56406	56242 56422	56258 56438	56273 56453	56288 56468	56303 56483	56317 56497	56500	56511
	0,66 a 1,00	CODE	56211 56391	56227 56407	56243 56423	56259 56439	56274 56454	56289 56469	56304 56484	56318	56501	56512
	0,95 a 1,40	CODE	56212 56392	56228 56408	56244 56424	56260 56440	56275 56455	56290 56470	56305 56485	56319	56502	56513
	1,30 a 1,90	CODE	56213 56393	56229 56409	56245 56425	56261 56441	56276 56456	56291 56471	56306 56486	56320	56503	56514
	1,80 a 2,60	CODE	56214 56394	56230 56410	56246 56426	56262 56442	56277 56457	56292 56472	56307	56321	56504	56515
	2,50 a 3,60	CODE	56215 56395	56231 56411	56247 56427	56263 56443	56278 56458	56293 56473	56308	56322	56505	56516
	3,50 a 5,00	CODE	56216 56396	56232 56412	56248 56428	56264 56444	56279 56459	56294	56309	56323	56506	56517
	4,80 a 6,30	CODE	56217 56397	56233 56413	56249 56429	56265 56445	56280 56460	56295	56310	56324	56507	56518
	6,00 a 8,00	CODE	56218 56398	56234 56414	56250 56430	56266 56446	56281 56461	56296	56311	56325	56508	56519
	7,50 a 10,00	CODE	56219 56399	56235 56415	56251 56431	56267 56447	56282 56462	56297	56312	56326	56509	56520
	9,50 a 12,50	CODE	56220 56400	56236 56416	56252 56432	56268 56448	56283	56298	56313	56327	56510	
	12,00 a 16,00	CODE	56221 56401	56237 56417	56253 56433	56269 56449	56284	56299	56314	56328		
	15,00 a 20,00	CODE	56222 56402	56238 56418	56254 56434	56270	56285	56300	56315	56329		
	18,00 a 25,00	CODE	56223 56403	56239 56419	56255 56435	56271	56286	56301	56316			
	23,00 a 32,00	CODE	56224 56404	56240 56420	56256 56436	56272	56287	56302				
30,00 a 40,00	CODE	56225 56405	56241 56421	56257 56437								

— Spring steel (EN-10270-1-SH). Maximum temperature for EP, ES and CP models 250°C / AP 400°C.

— Vanadium-chrome steel (EN-1.8159).

— Stainless steel (EN-1.4310).

COEFFICIENT OF DISCHARGE										
DN ₁ x DN ₂	25 x 25	32 x 32	40 x 40	50 x 50	65 x 65	80 x 80	100 x 100	125 x 125	150 x 150	200 x 200
do	16	20	25	32	40	50	63	77	93	110
h	2,00	2,00	2,50	3,50	4,00	5,00	6,50	8,00	9,50	11,00
h/do	0,12	0,10	0,10	0,10	0,10	0,10	0,10	0,10	0,10	0,10
COEFFICIENT OF DISCHARGE α_d	SATURATED STEAM GASES				0,25					
	LIQUIDS				0,25					

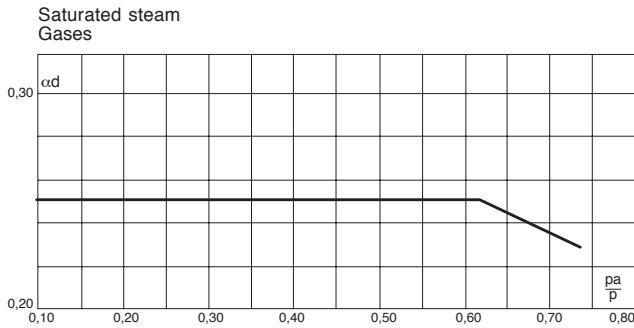
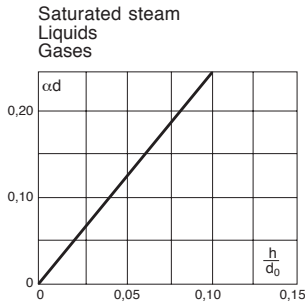
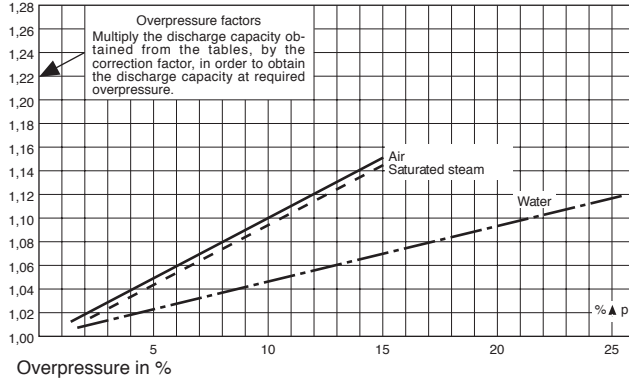
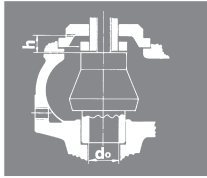

DN ₁ x DN ₂	25 x 25			32 x 32		
do	16			20		
$A_o = \frac{\pi \cdot d_o^2}{4}$	201			314		
p [bar]	SET PRESSURE IN bar					
	I	II	III	I	II	III
0,5	43	49	1804	66	77	2829
1,0	56	68	2551	87	107	4001
1,5	69	86	3124	108	134	4900
2,0	82	103	3607	128	160	5858
2,5	95	120	4033	148	187	6326
3,0	108	137	4418	169	214	6930
3,5	121	154	4772	189	241	7485
4,0	134	171	5102	209	267	8002
4,5	147	188	5411	229	294	8487
5,0	159	205	5704	249	321	8946
6,0	185	239	6248	289	374	9800
7,0	211	274	6749	329	428	10585
8,0	236	308	7215	369	481	11316
9,0	261	342	7652	408	535	12002
10,0	287	376	8066	448	588	12652
12,0	337	445	8836	527	695	13859
14,0	388	513	9544	606	802	14969
16,0	439	582	10203	685	909	16003
18,0	489	650	10822	764	1016	16974
20,0	539	718	11407	842	1123	17892
22,0	590	787	11964	921	1230	18765
24,0	640	855	12496	1000	1337	19600
26,0	691	924	13006	1080	1444	20400
28,0	742	992	13497	1160	1551	21170
30,0	794	1060	13971	1240	1658	21913
32,0	845	1129	14429	1320	1764	22632
34,0		1197	14873		1871	23328
36,0		1266	15305		1978	24005
38,0		1334	15724		2085	24662
40,0		1403	16132		2192	25303

DISCHARGE CAPACITY

40 x 40	50 x 50	65 x 65	80 x 80	100 x 100	125 x 125	150 x 150	200 x 200
25	32	40	50	63	77	93	110
491	804	1257	1964	3117	4657	6793	9503

I - Saturated steam in Kg/h.

II - Air at 0°C and 1,013 bar in [Nm³/h].

III - Water at 20°C in l/h.

For other, not so dense liquids, other than water at 20°C apply:

$$V_L = \sqrt{\frac{\rho_A}{\rho_L}} \cdot V_A \quad \text{ó} \quad V_A = V_L \cdot \sqrt{\frac{\rho_L}{\rho_A}}$$

V_A = Water flow according to table.

V_L = Liquid flow.

ρ_A = Water density at a 20°C.
($\rho_A=998 \text{ Kg/m}^3$).

ρ_L = Liquid density.

I	II	III	I	II	III	I	II	III	I	II	III	I	II	III	I	II	III	I	II	III	I	II	III
104	120	4424	170	196	7244	266	307	11325	416	480	17695	660	762	28082	986	1138	41957	1438	2148	60957	2012	3005	85617
136	167	6256	223	274	10244	349	428	16016	545	669	25024	864	1062	39715	1291	1586	59336	1884	2994	86206	2635	4189	121080
168	209	7662	275	342	12546	431	535	19615	673	836	30648	1068	1327	48640	1596	1983	72672	2328	3743	105580	3256	5236	148293
200	251	8847	328	411	14487	513	642	22650	801	1003	35389	1271	1592	56165	1899	2379	83914	2770	4492	121913	3876	6283	171234
232	293	9892	380	479	16197	594	749	25323	928	1171	39566	1473	1858	62794	2200	2776	93819	3209	5240	136303	4490	7331	191445
264	334	10836	432	548	17743	675	856	27740	1055	1338	43343	1674	2123	68788	2501	3172	102773	3648	5989	149313	5104	8378	209717
295	376	11704	483	616	19165	756	963	29963	1181	1505	48815	1874	2388	74299	2800	3569	111008	4085	6737	161276	5714	9425	226521
327	418	12512	535	685	20488	836	1070	32032	1307	1672	50048	2074	2654	79429	3098	3965	118672	4519	7486	172411	6322	10472	242161
358	460	13271	586	753	21731	917	1177	33975	1433	1839	53084	2274	2919	84247	3397	4362	125871	4955	8234	182870	6932	11519	256850
389	502	13989	638	821	22906	997	1284	35812	1558	2007	55955	2473	3185	88805	3694	4758	132680	5388	8983	192782	7538	12567	270744
452	585	15324	740	958	25093	1157	1498	39231	1808	2341	61296	2869	3715	97280	4287	5551	145343	6253	10480	211160	8748	14661	296585
514	669	16552	842	1095	27103	1317	1712	42374	2058	2676	66207	3266	4246	105075	4879	6344	156989	7117	11977	228079	9956	16756	320349
577	752	17695	944	1232	28974	1476	1926	45300	2306	3010	70778	3660	4777	112330	5469	7137	167828	7977	13475	243826	11160	18850	342467
639	836	18768	1046	1369	30732	1635	2140	48047	2555	3344	75072	4054	5308	119144	6057	7930	178008	8836	14972	258617	12361	20945	363241
700	920	19783	1147	1506	32394	1793	2355	50646	2801	3679	79132	4446	5839	125589	6643	8723	187637	9689	16469	272606	13555	23039	382890
824	1087	21671	1350	1780	35486	2110	2783	55480	3297	4348	86685	5233	6900	137575	7818	10309	205546	11404	19463	298625			
945	1254	23408	1552	2054	38330	2426	3211	59926	3791	5017	93631	6016	7962	148598	8988	11895	222016						
1068	1421	25024	1754	2327	40976	2742	3639	64063	4285	5685	100096	6800	9023	158858	10160	13481	237345						
1192	1589	26542	1955	2601	43482	3057	4067	67949	4777	6354	106167	7581	10085	168495	11327	15067	251742						
1315	1756	27978	2157	2875	45813	3372	4495	71625	5269	7023	111910	8362	11146	177609		16653	265359						
1439	1923	29343	2359	3149	48049	3688	4923	75121	5762	7692	117372		12208	186278									
1563	2090	30648	2561	3423	50185		5351	78461	6256	8361	122591		13269	194561									
1688	2257	31899		3697	52234		5779	81685		9030	127597		14331	202505									
1813	2425	33103		3970	54206		6207	84748		9699	132414												
1938	2592	34265		4244	56109		6635	87722		10368	137061												
	2759	35389		4518	57949		7064	90599		11036	141556												
	2926	36478																					
	3094	37536																					
	3261	38564																					
	3428	39566																					

Calculus according to ISO-4126-1:2004
"Safety valves".

FACT LIST FOR SAFETY VALVE CALCULS Calculus according to ISO-4126-1:2004 "Safety valves" 1)				Customer:			
				Theme:			
				Leaf:		Of:	
1	Consultation / Bid / Order						
2	Position N°:						
3	N° of units						
4	Regulation						
5	SERVICE CONDITIONS	Fluid					
6		Calculation temperature °C					
7		State at moment of dischar. l = liquid, s = steam, g = gas					
8		Molecular mass kg/kmol					
9		Adiabatic exponent æ		Compressibility coe. Z			
10		Density at moment of discharge kg/m³					
11		Coefficients ψ max		χ			
12		Viscosity cSt		cPs			
13		Working pressure abs. bar					
14		Set pressure abs. bar					
15		External back pressure abs.					
16		constant		variable		bar	
16		Rated pressure abs. bar					
17	Discharge capacity		Required: kg/h, Nm³/h, l/h				
18			Possible: 1) Kg/h, Nm³/h, l/h				
19	VALVE CONSTRUCTION	Opening: Full lift / Normal / Progressive					
20		Manufacturer type					
21		Materials	Body				
22			Seat				
23			Plug				
24			Spring				
25			Joint				
26		Manual discharge action yes / no					
27		Cover Closed / Open					
28		Bellows yes / no					
29		Body with drainage yes / no					
30		Diameter of narrowest flow do mm					
31		Section of narrowest flow A0		Necessary A0		mm²	
32			Chosen A0		mm²		
33	Allowed discharge coefficient αd						
34	CONNECTIONS	Input / Output	DN	Flange mm			
35				Thread inch			
36				Welding (soldering) ends			
37		PN	bar				
38	Shape of joint surfaces (DIN-2526)						
39	OBSERVATIONS	Unit weight approx. Kg					
40							
41							
42							
43	ACCEPTANCE	Certificate according to EN-10204 2.2					
44		Certificate according to EN-10204 3.1					
45							
Date:							
Department:							
Name:							