

PRESSURE REDUCING VALVE

EUROBRASS 142

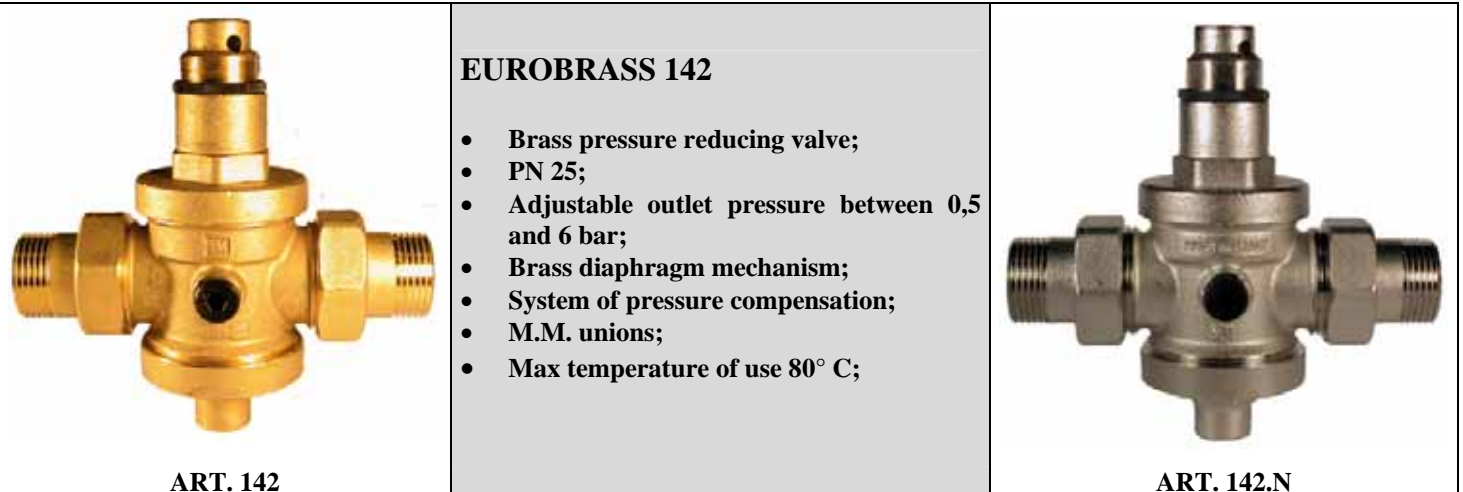

FIELDS:

The pressure reducing valves series EUROBRASS 142 are suitable for reduction and control of pressure in plants with the following characteristics:

Max inlet pressure:	25 bar
Field of action (outlet pressure):	0,5 - 6 bar
Max temperature of use:	80° C
Threading of connection:	ISO 228/1
Tested according to rules:	DIN EN 1567
Suitable fluids:	Water, compressed air
Reduction rate :	10 : 1

MATERIALS:

Metal of the body:	Brass alloy CW617N UNI EN 12165 - CB753S EN 1984
Metal of the inner parts:	Brass alloy CW614N UNI EN 12164
Seat:	Stainless steel AISI 303
Bar:	Brass alloy CW614N UNI EN 12164 Stainless steel AISI 303¹
O-rings:	NBR 70sh
Flat gaskets:	Fasit Italy
Plastic parts:	Ultramid® A3K (BASF)

¹ Sizes from 1"¼ to 2"

MAIN DIMENSIONS OF THE PRESSURE REDUCING VALVES EUROBRASS 142

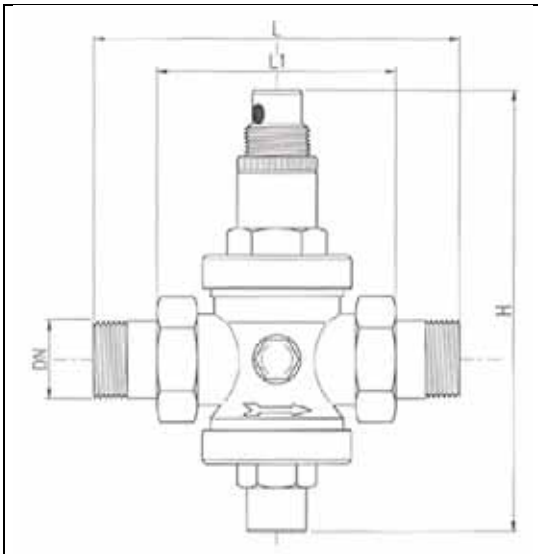

ITEM	DN	H	L	L1
142.12	1/2"	120	112	75
142.34	3/4"	120	134	88
142.33	1"	160	140	93
142.114	1" 1/4	220	185	131
142.112	1" 1/2	220	190	131
142.58	2"	250	260	140

DISCHARGE AND HEADLOSS CHART:

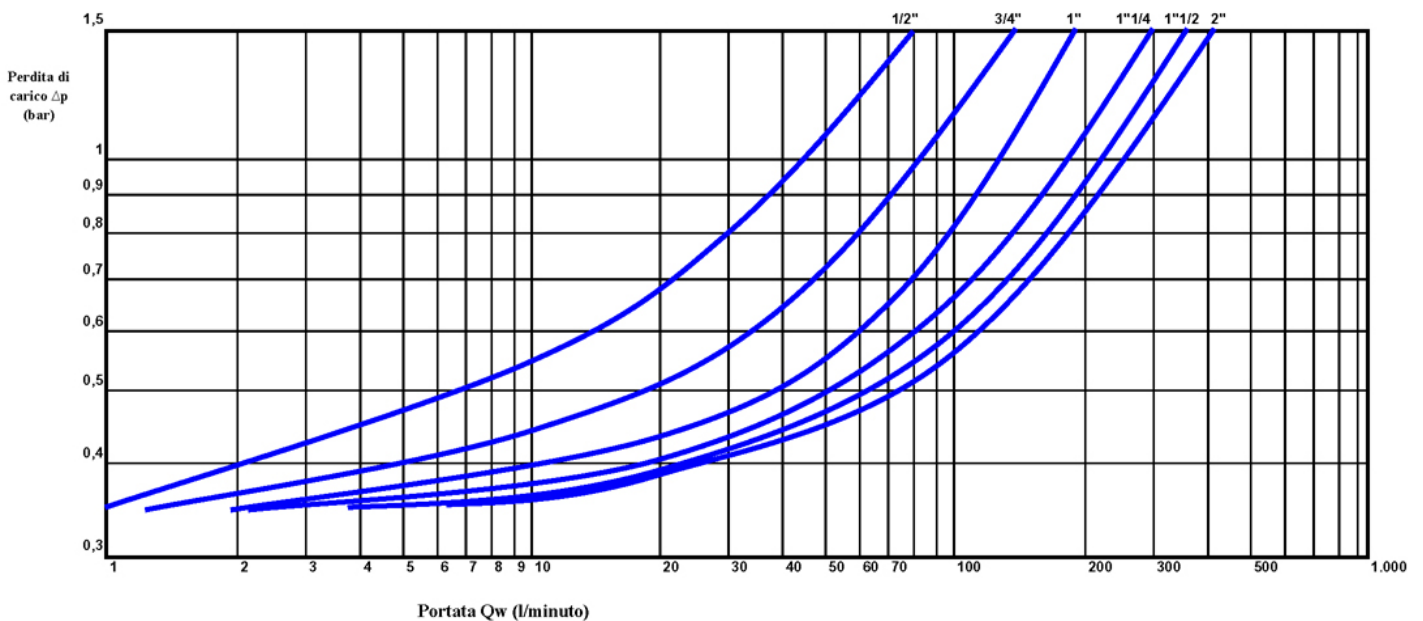

BEST HYDRAULIC DISCHARGE OF PRESSURE REDUCERS EUROBRASS 142²

In order to choose the best pressure reducers for any plant, we suggest to follow the indications mentioned in the underexposed table with the best running pressure of the valves Eurobrass 142; the values are exposed both in litres/minute and cbm/hour, and indicate the field of use where you can obtain the best functioning, silence and smaller loss of charge of the valves.

MODEL	SIZE	AVERAGE HYDRAULIC DISCHARGE	
		L/min	Cbm/hour
EUROBRASS 142	1/2"	20 - 50	1,2 - 3
EUROBRASS 142	3/4"	50 - 75	3 - 4,5
EUROBRASS 142	1"	75 - 95	4,5 - 6
EUROBRASS 142	1" 1/4	95 - 130	6 - 8
EUROBRASS 142	1" 1/2	110 - 140	7 - 8,5
EUROBRASS 142	2"	120 - 160	7,5 - 10

INSTALLATION OF THE PRESSURE REDUCING VALVE

The pressure reducers EUROBRASS 142 don't get the effects – for their functioning – of the gravity force; therefore they can be installed in the plant in any position:

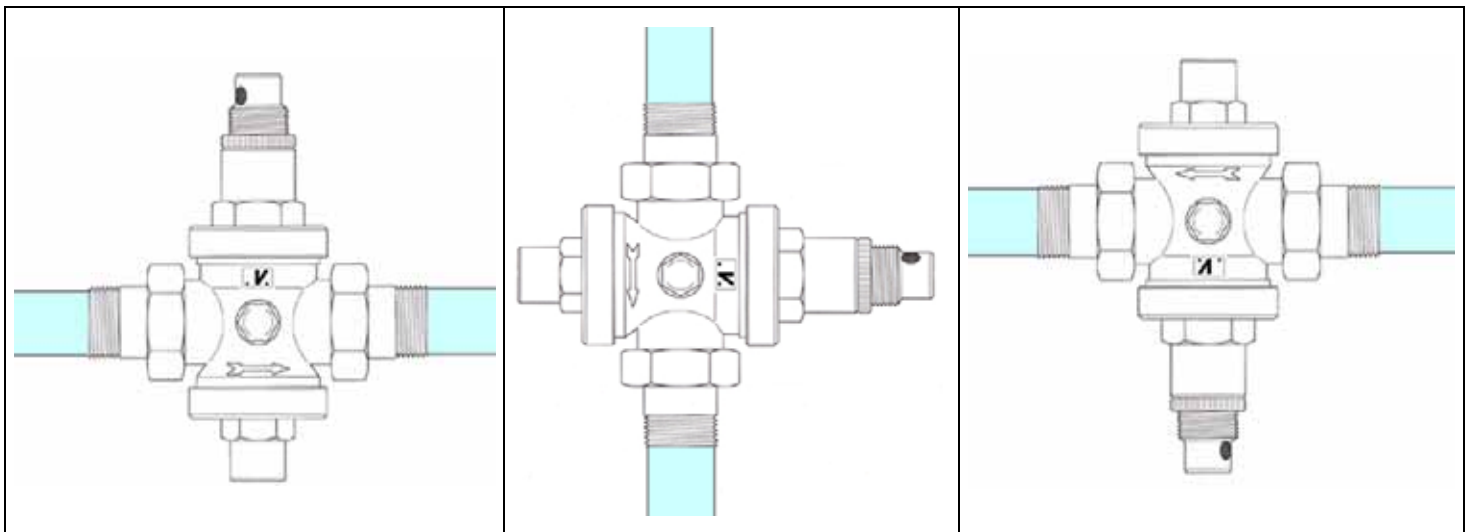

Pressure reducing valves can be damaged by dirty water; therefore we advise to install a self-cleaning filter upstream before the pressure reducer, in order to protect the valve and any other mechanism (thermostatic mixers, taps, etc.).

When there is a device which produce or store hot water or pipes are exposed to sudden changes in temperature, an increase of outlet pressure may occur; this event is due to the raise in pressure that follows the temperature rising; an expansion vessel between downstream the pressure reducing valve will avoid this problem.

We recommend moreover to install a Stopshock valve to prevent water hammer which would damage the inner parts of the pressure reducer and other devices in the waterworks.

² Test by ISTITUTO GIORDANO SPA - Bellaria - Italy

recommended installation of the pressure reducing valve:

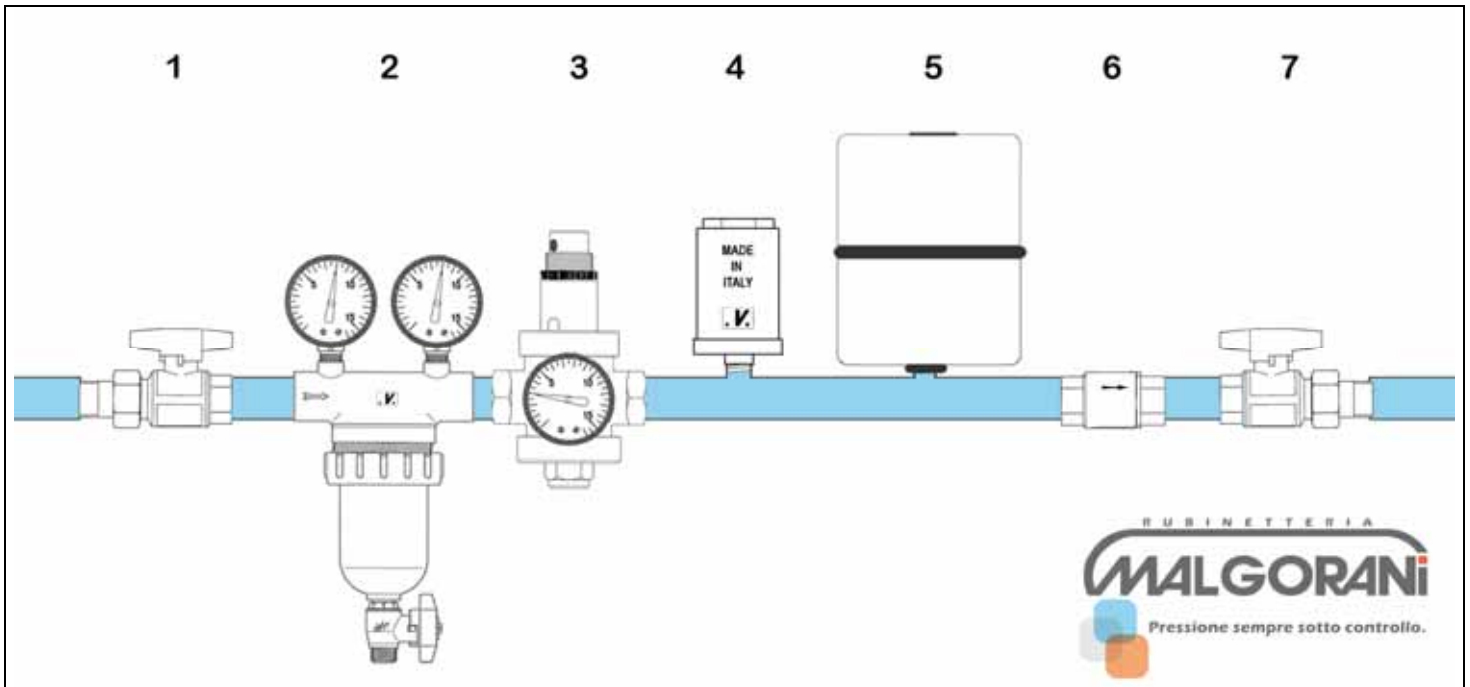

- 1 – BALL VALVE
- 2 – NEPTUN SELF-CLEANING FILTER
- 3 – EUROBRASS PRESSURE REDUCER

- 4 – STOPSHOCK VALVE
- 5 – EXPANSION VESSEL
- 6 – CHECK VALVE

- 7 – BALL VALVE

HOW TO REGULATE THE PRESSURE

All Malgorani pressure reducers are tested before being packaged; during the proof they are pre-set at the outlet pressure of 3 bars; the outlet pressure can be easily modified when the valve is installed on the plant.

In order to modify the outlet pressure, you should only loosen the fixing ring and turn the spring holder as indicated in the pictures sequence. By turning clockwise the pressure increases, while counter-clockwise the pressure decreases.

A right setting should be made while the plant is closed.

