

## MAW® Y-STRAINERS FOR INDUSTRIAL APPLICATION

### Series 630N

#### Attributes of Design

MAW® Series 630N Y-Strainers are compact, of a cylindrical shape and strong enough to handle hot water, steam, air and gases. Gases, being readily compressible, will flow through Y-strainers of the same size as a pipeline easily, with little pressure loss.

They are designed with adequate safety margins. This means sufficiently heavy wall thickness and blow off connections. As an example, in improperly trapped steam lines, condensate can collect in low points and become a slug of water traveling at very high velocity down the line. Even the slight change in direction caused by a Y-strainer can produce a tremendous shock which can break the strainer wall.

Raised Flange ends; and machined slots to better accommodate the assembling gaskets.

Precise Machine seat slot; to accommodate the screen and avoid dirt to by pass the strainer.

Marking and Tagging; positive flow marking by an arrow, raised symbols of Heat Number, Design Pressure and Nominal Size. Riveted steel name plate showing working limits and PED approval.

Blue painted RAL 5002 Inner painted wall; for better preservation during storage periods.

Supporting end rings; to provide greater consistency and ease the screen placement into the strainer chamber.

High Quality stainless steel screen; made out of high resistance wire, rugged and braided type. Thick enough to avoid deformation.

Reinforced Graphite Gasket; with stainless steel layers to resist high fluid temperature.

Removable bolting cover; to ease maintenance operations.

Standard Blow Off connection; for in line emptying of condensate or water.

Tapped Drainage Screw sealing; with a metallic gasket thus avoiding the gasket replacement on every emptying operation. Leakage proof.

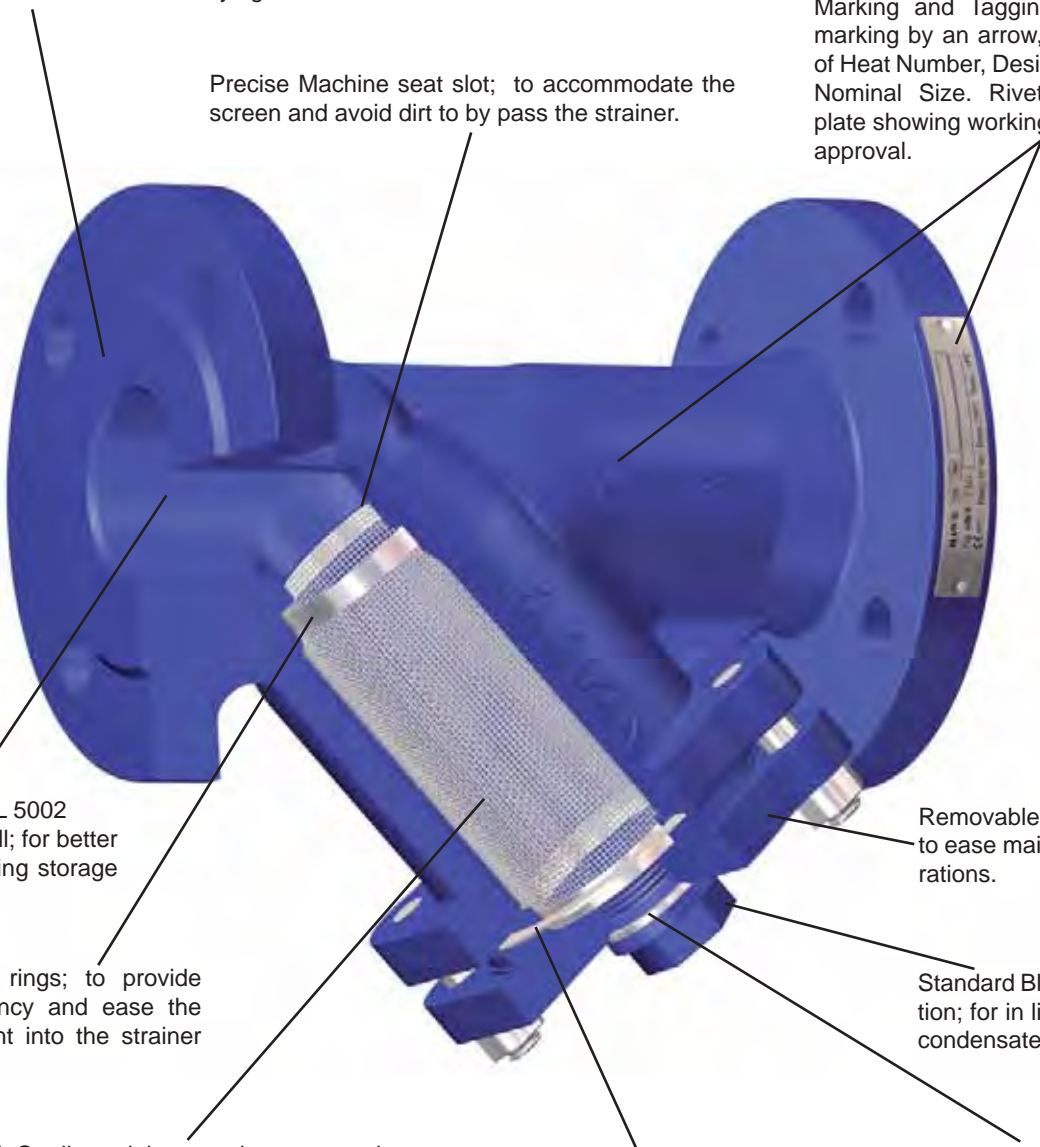

# MAW® Y-STRAINERS FOR INDUSTRIAL APPLICATION

## Series 630N

### Parts and Materials

Part	Description	Material	Specification
01	Body	Cast Iron	EN 1561 / EN GJL 250 - EN JL 1040 (Former GG-25)
02	Cover	Cast Iron	EN 1561 / EN GJL 250 - EN JL 1040 (Former GG-25)
03	Gasket	Graphite	CrNi Steel Reinforced
04	Screen	St. Steel	EN 10088 / X5CrNi18-10 (1.4301)
05	Studs-Nuts	Steel	25 CrMo4, 1.721-C35E, 1.181
06	Draining Plug Gasket	St. Steel	A4 (WNR-1.4571)
07	Draining Plug	Ductile Iron	EN 1563 / EN JS1030 (Former GGG-40)

*Other Material Options on request*

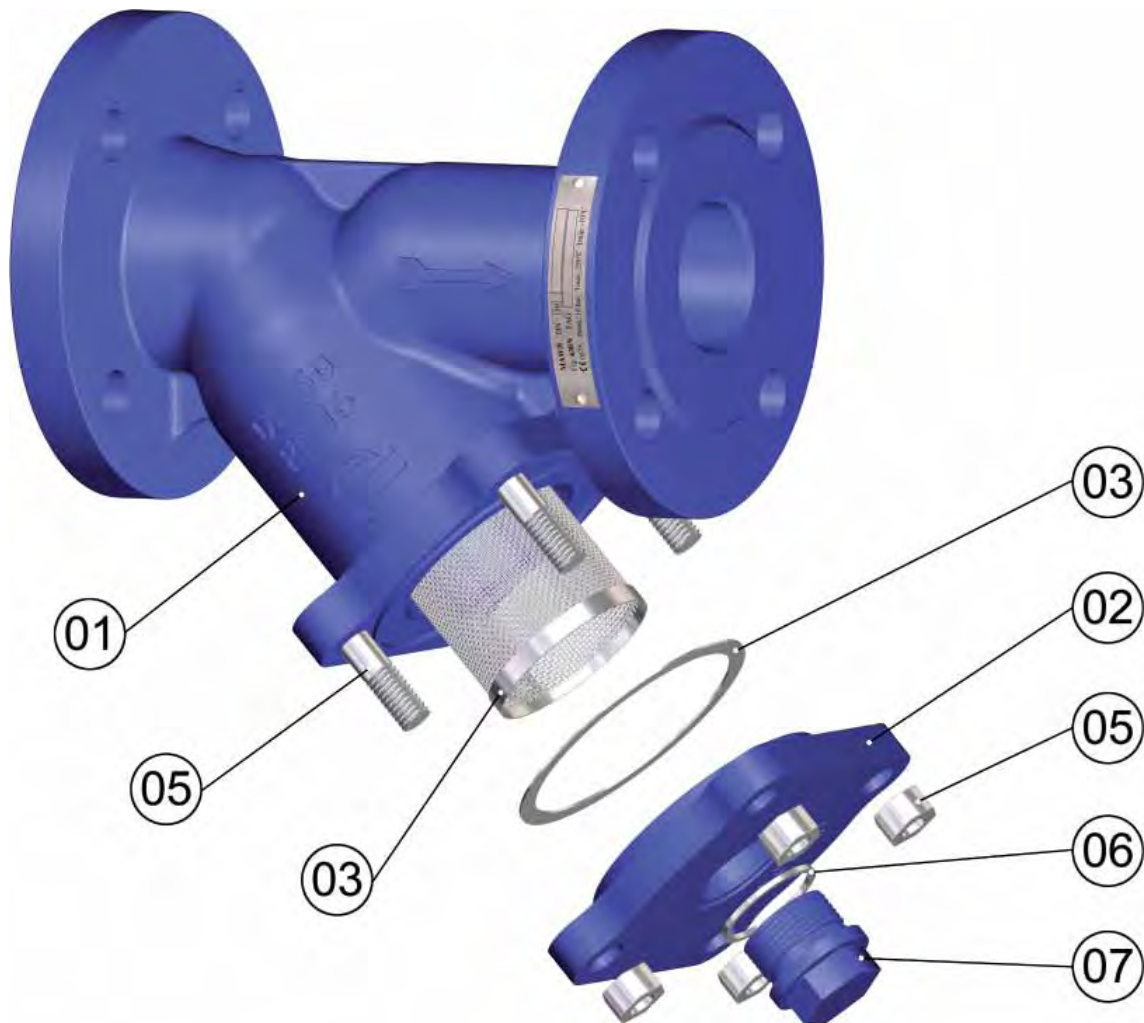

# MAW® Y-STRAINERS FOR INDUSTRIAL APPLICATION

## Series 630N

### Dimensions

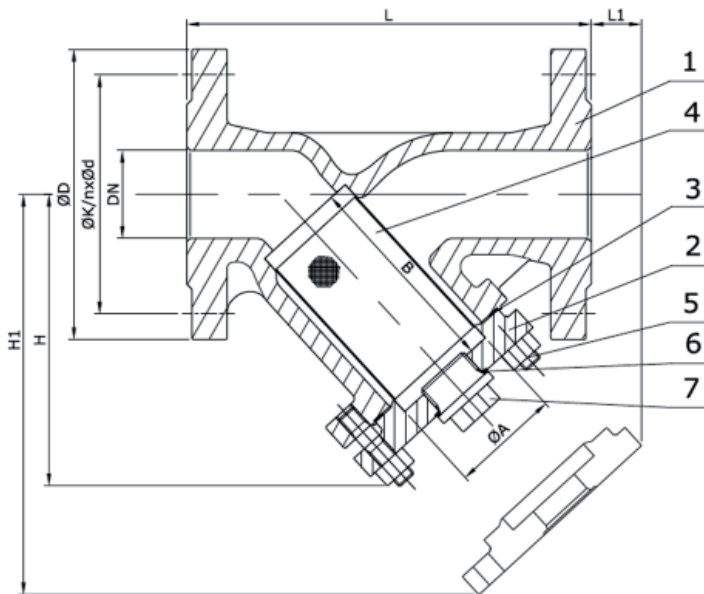

DN	L	H	H1	L1	ØA	B	ØD	ØK	nxØd	Weight (kg)
15	130	90	135	10	23	56	95	65	4 x 14	2,5
20	150	100	150	10	28	68	105	75	4 x 14	4,0
25	160	115	180	25	36	82	115	85	4 x 14	5,0
32	180	125	205	35	42	98	140	100	4 x 18	7,0
40	200	150	235	45	50	114	150	110	4 x 18	9,5
50	230	160	250	45	61,5	119	165	125	4 x 18	12,5
65	290	180	285	25	78,5	134	185	145	4 x 18	17,0
80	310	215	330	40	89,5	149	200	160	8 x 18	21,5
100	350	235	365	55	109,5	169	220	180	8 x 18	29,0
125	400	275	425	65	137,5	199	250	210	8 x 18	42,0
150	480	305	480	50	160	224	285	240	8 x 22	61,0
200	600	390	610	80	210	284	340	295	12 x 22	118,0
250	730	540	915	230	258	434	405	355	12 x 26	157,0
300	850	680	1.110	350	308	555	460	410	12 x 26	258,0

Dimensions are expressed in mm. Data can be altered without notice by our Design Department for the product benefit.

#### Manufacture Design Standards:

QA certified to ISO 9001:2000

According to Pressure Equipment Directive PED 97/23/CE by a recognised Notify Body

Testing Standard: EN 12266-1 (Former DIN 3230 part 3) / BS6755 Part 1

Marking Standard: EN 19

Face to Face length: EN-558-1 Series 1 (Former DIN 3202 F1)

Body End Connections: Flanges sized and drilled to EN 1092-2 (Former DIN 2533) PN 16

#### Operating Parameters:

Working Pressure: 0...16bar-g

Working Temperature: -10°C ... +300°C

See Engineering Data for Pressure / Temperature relationship

#### Main Applications:

Saturated Steam, Vapours, Gases, Compressed Air and Lubricants, etc.