

VALVOLE A FARFALLA BUTTERFLY VALVES

VF-73



SCARTAMENTO

Le valvole sono costruite in conformità della tabella ISO 5752-5 short (DIN 3203/3-K1).

FLANGIA SUPERIORE

A norme ISO 5211 per il montaggio di un attuatore elettrico o pneumatico.

ACCOPIAMENTO FLANGE

Sono idonee ad essere inserite tra flange UNI PN 10, UNI PN 16 o ANSI 150 FF o RF.

PRESSIONE DI ESERCIZIO

Tenuta bidirezionale	16 bar -----DN40 ~ DN300mm
	10 bar -----DN350 ~ DN900mm

PROVA IDRAULICA DI TENUTA

Al 110% della pressione massima	18 bar ----- DN40 ~ DN300mm
	11 bar ----- DN350 ~ DN900mm

PROVA IDRAULICA DEL CORPO

Al 150% della pressione massima	24 bar ----- DN40 ~ DN300mm
	15 bar ----- DN350 ~ DN900mm

COME INSTALLARE LA VALVOLA

La valvola può essere inserita in qualsiasi tipo di flangia. NON VANNO UTILIZZATE GUARNIZIONI , in quanto il design della valvola elimina la necessità di guarnizioni. Per un'installazione corretta, lo spazio tra le flange deve essere sufficiente a permettere l'inserimento della valvola senza forzare il manicotto di gomma.

Controllare che il bordo del manicotto sia in linea con le flange. Ruotare leggermente l'albero lasciando il disco all'interno del corpo ed avvitare a mano le viti (o i bulloni). APRIRE LENTAMENTE la valvola ruotando in senso orario per verificare che il disco si muova senza impedimenti. RIPORTARE IL DISCO IN POSIZIONE CHIUSA e stringere tutte le viti (o bulloni). Controllare ancora il corretto funzionamento del disco.

MECCANISMO DI RITENZIONE DELL'ASTA

In tutte le valvole sino al DN 300, l'asta è posizionata nel corpo in base ad uno speciale design (meccanismo "a Q" di ritenzione dell'asta), che permette di rimuovere l'albero anche senza speciali utensili. ATTENZIONE! Se non intendete smontare la valvola, accertatevi di non posizionare il disco a 135° di apertura.

FACE TO FACE

Valve body are designed to meet ISO 5752 table 5 short (DIN 3203/3 – K1).

MOUNTING FLANGE

The mounting flange on the valve body are designed to comply with ISO 5211, so they can be easily fitted with an actuator.

FLANGE REQUIREMENT

Valve body are designed to suit ANSI 150, UNI PN 10 or UNI PN 16 flanges, either flat face or raised face.

PRESSURE RATING

Bi-directional bubble-tight shut off to	16 bar-----DN40 ~ DN300mm
	10 bar-----DN350 ~ DN900mm

and tested to 110% of full rating	18 bar----- DN40 ~ DN300mm
	11 bar----- DN350 ~ DN900mm

SHELL TESTING

The body strenght can stand 150% of full rating	24 bar----- DN40 ~ DN300mm
	15 bar----- DN350 ~ DN900mm

INSTALLATION INSTRUCTIONS

The valve is designed for using between all types of flat or raised face flanges. DO NOT USE FLANGE GASKETS. The butterfly valve design eliminates the need for gasket. For proper installations, the space between flanges must be sufficient to permit valve insertion without disturbing the rubber liner flange seal. Note that the disc sealing edge is in line with the flat of the shaft. Rotate the stem to position the disc within the body, place the valve between flanges and hand-tighten the bolts. SLOWLY OPEN the valve counterclockwise to check for adequated disc clearance. RETURN THE DISC TO THE CLOSED POSITION and cross tighten all bolts, again check for adequated disc clearance.

STEM RETAINING MECHANISM

The stem is retaining in the body by means of special "Q" type design when the valve size is under DN 350 mm, and hence the stem can be removed from the body and disc without any special tools. Unless you do intend to disassemble the valve, otherwise do not position the disc around 135°.



CORPO FUSO IN ACCIAIO INOX INVESTMENT CASTING STAINLESS STEEL BODY

PRESSURE RATING:
DN 40-300 **16 BAR**

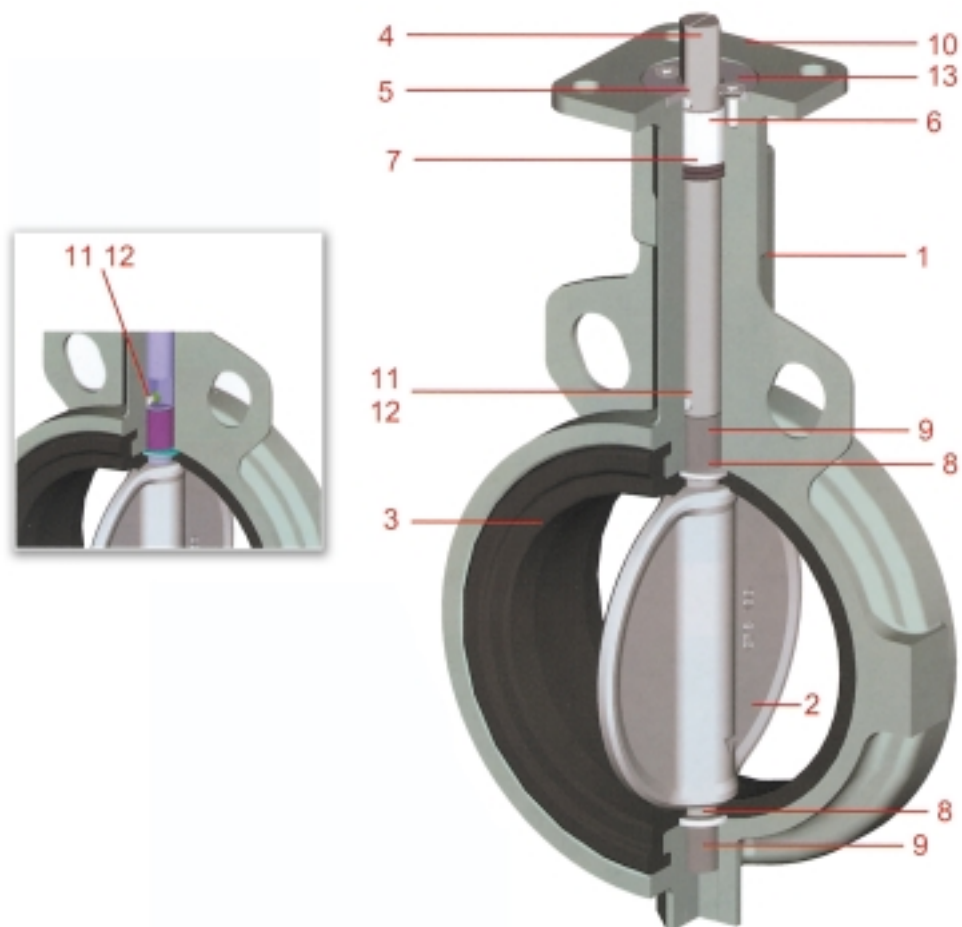

La serie VF-73 è disponibile anche con corpo fuso in acciaio inox, nelle misure dal DN 40 al DN 300, sia nella versione wafer che lug. Questa linea di valvole ha lo stesso design delle valvole con corpo in ghisa, e, in aggiunta, tutti i vantaggi dei particolari quali le boccole in RTFE+316 (9), il sistema di ritenzione dell'asta (10), la leva o il riduttore in acciaio inox, ecc., che raggiungono un'alta resistenza alla corrosione esterna per l'uso in ambienti aggressivi.

Un doppio sistema di tenuta è adottato sull'asta, assicurando una tenuta affidabile e duratura. Oltre all'albero con tenuta autoallineante, gli o-ring (8) possono ulteriormente prevenire qualsiasi perdita e/o distorsione dell'asta durante le operazioni. Questi anelli non sono esposti al fluido, per cui non vengono mai corrosi. La valvola può essere corredata da un dispositivo antistatico (11), sebbene valvola, disco ed albero siano isolati tramite il manicotto in elastomero e le boccole dell'asta. Il dispositivo assorbe la corrente statica che potrebbe risultare dall'attrito tra fluido e disco; per questo motivo lo consigliamo per prevenire eventuali danni che potrebbero essere causati dalla corrente statica.

VF-73 valves could be also available with stainless steel investment cast bodies (1) and discs (2) from size DN 40 up to DN 300 in both wafer and lug styles. This line of valves has the same design features of VF-730 / 733 valve, plus the advantage parts like RTFE+SS316 bushings (9), stem retainer (10), stainless steel lever operator set and gear box etc., to reach a high integrity corrosion resistance exterior for use in aggressive environment.

Double sealing system is adopted as a stem seal. As the secondary seal self-aligning stem seal has been chosen; the back-up ring (8) could counteract any displacement and/or tilt of stem during. This seal ring does not expose to fluids, so it's never corroded. The double sealing system secures tighter and reliable stem seal.

Anti static device (11) has to be equipped with this valve, since the valve disc & stem was isolated by rubber liner and stem bushings. It will collect the static, which resulted by the friction between the fluids and disc. In order to prevent the dangers caused by static, the antistatic device is required.



MATERIALI MATERIALS

VF-730 WAFER VF-733 LUG VF-737 FLANGE

DN 40 ~ DN 600

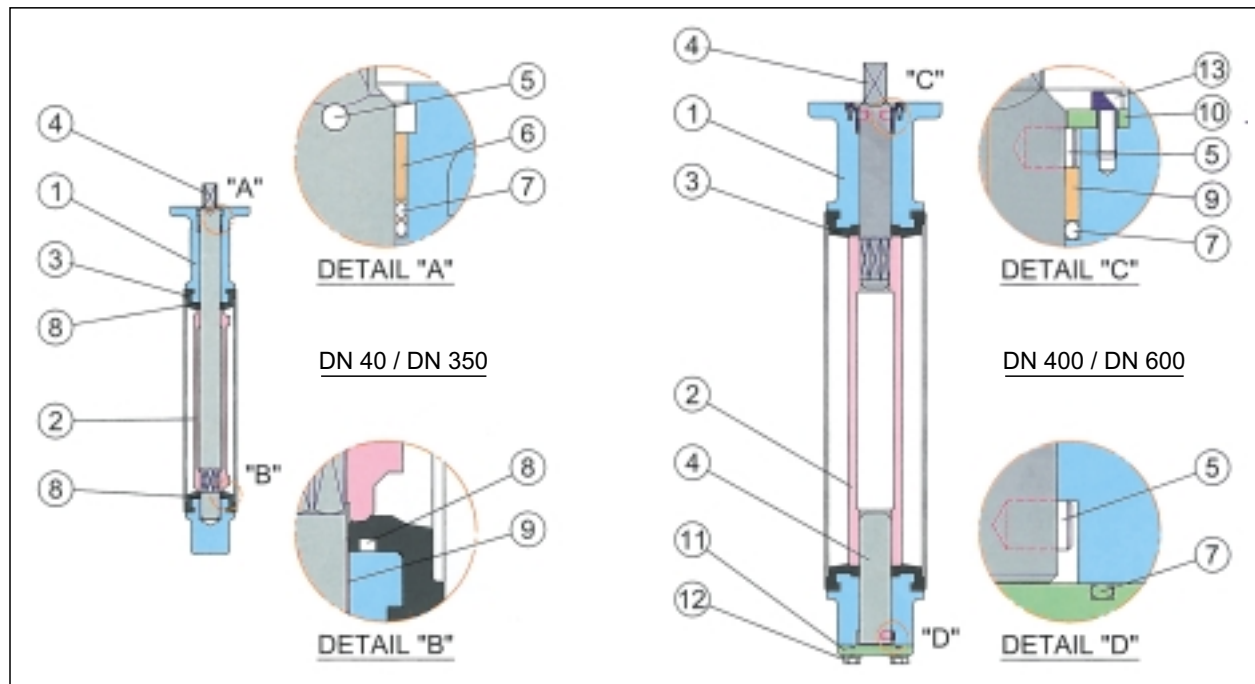

No.	MATERIALE MATERIALS	ASTM	NOTE REMARK
1	GHISA GG25 CAST IRON	A 126-B	
	GHISA SFEROIDALE GG40 DUCTILE IRON	A-536-65-45-12	
	ACCIAIO INOX STAINLESS STEEL	A351 CF8 A351 CF8M	
2	GHISA SFEROIDALE GG40 DUCTILE IRON	A-536-65-45-12	Nylon 11 coating
	ACCIAIO INOX STAINLESS STEEL	A351 CF8 A351 CF8M	
	BRONZO ALLUMINIO ALU-BRONZE	B148-954	
3	NBR (NITRILE)		-10° ~ +80°C
	EPDM		-20° ~ +120°C
	EPT		-20° ~ +140°C
	NEOPRENE (CR)		0° ~ +80°C
	SILICON		-20° ~ +180°C
	HYPALON (CSM)		-20° ~ +135°C
	VITON		-18° ~ +204°C
4	ACCIAIO INOX STAINLESS STEEL	A182 F6A	
		A182 F304	
		A182 F316	
5	ACCIAIO INOX STAINLESS STEEL	A182 F316	
6	DELRIN		
7	NBR (NITRILE)		
8	PLASTICA PLASTIC		
9	BRONZO BRONZE	B62	Per corpo in ghisa GG25 o in ghisa sferoidale GG40 / For cast iron and ductile iron body
	ACCIAIO STEEL	A6	Per corpo in ghisa GG25 o in ghisa sferoidale GG40 / For cast iron and ductile iron body
10	ACCIAIO INOX STAINLESS STEEL	A240 304	Per corpo in acciaio inox / For stainless steel body
	GHISA GG25 CAST IRON	A126-B	Per corpo in ghisa GG25 o in ghisa sferoidale GG40 / For cast iron and ductile iron body
11	ACCIAIO INOX STAINLESS STEEL	A351 CF8	Per corpo in acciaio inox / For stainless steel body
	ACCIAIO STEEL		
12	ACCIAIO STEEL		
13	ACCIAIO STEEL		



MATERIALI MATERIALS
VF-730 WAFER VF-737 FLANGE
DN 700 ~ DN 900

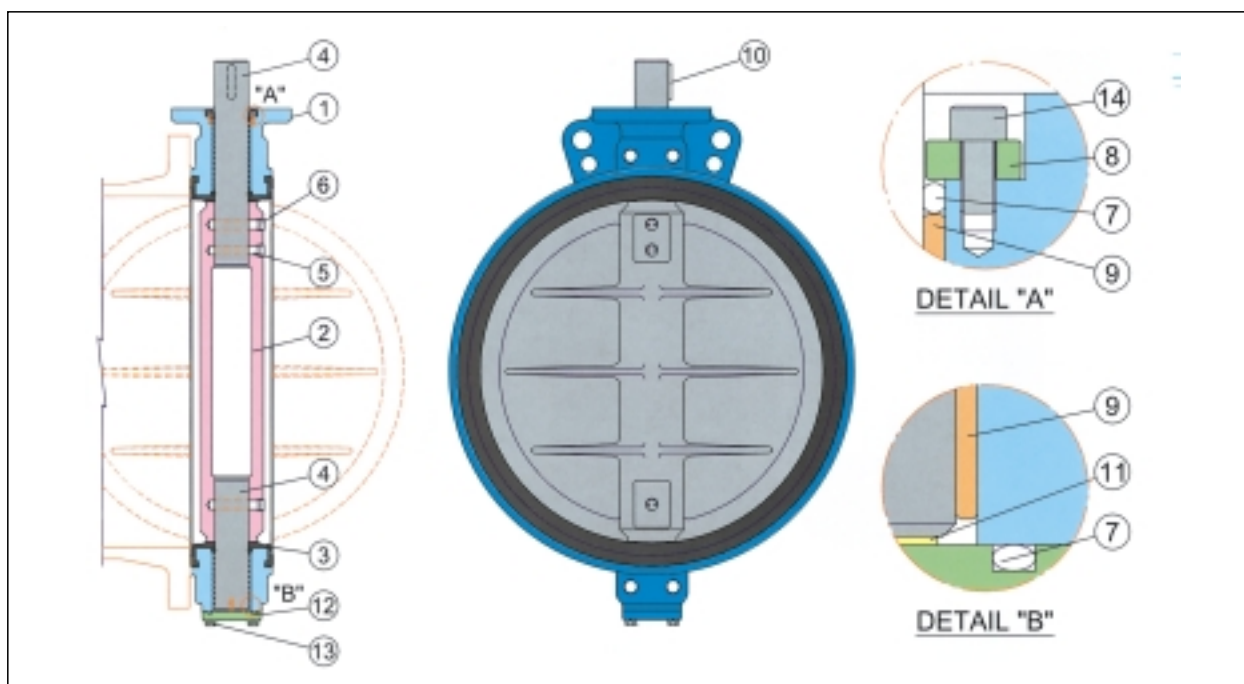

No.	MATERIALE MATERIALS	ASTM	NOTE REMARK
1	CORPO BODY	GHISA SFEROIDALE GG40 DUCTILE IRON	A-536-65-45-12
		ACCIAIO INOX STAINLESS STEEL	A351 CF8 A351 CF8M
2	FARFALLA DISC	GHISA SFEROIDALE GG40 DUCTILE IRON	A-536-65-45-12
		ACCIAIO INOX STAINLESS STEEL	A351 CF8 A351 CF8M
		BRONZO ALLUMINIO ALU-BRONZE	B148-954
3	SEDE SEAT	NBR (NITRILE)	-10° ~ +80°C
		EPDM	-20° ~ +120°C
		EPT	-20° ~ +140°C
		NEOPRENE (CR)	0° ~ +80°C
		SILICON	-20° ~ +180°C
		HYPALON (CSM)	-20° ~ +135°C
		VITON	-18° ~ +204°C
4	ASTA STEM	ACCIAIO INOX STAINLESS STEEL	A182 F6A A182 F304 A182 F316
		ACCIAIO INOX STAINLESS STEEL	A182 F316
		ACCIAIO INOX STAINLESS STEEL	
5	PERNO DI TENUTA PIN	ACCIAIO INOX STAINLESS STEEL	
6	SPINA PLUG	ACCIAIO INOX STAINLESS STEEL	
7	O-RING	NBR (NITRILE)	
8	COPERCHIO SUPERIORE UPPER COVER	ACCIAIO STEEL	A6
		ACCIAIO INOX STAINLESS STEEL	A240 304
9	BOCCOLA BUSH	BRONZO BRONZE	B62
10	CHIAVE KEY	ACCIAIO STEEL	
11	CUSCINETTO BEARING	BRONZO BRONZE	B62
12	COPERCHIO INFERIORE BOTTOM COVER	GHISA GG25 CAST IRON	A126-B
13	BULLONI BOLT	ACCIAIO STEEL	
14	BULLONI BOLT	ACCIAIO STEEL	

DIMENSIONI DIMENSIONS

VF-730 WAFER

DN 40 ~ DN 900

PRESSURE RATING:
 DN 40-300 **16 BAR**
 DN 350-900 **10 BAR**

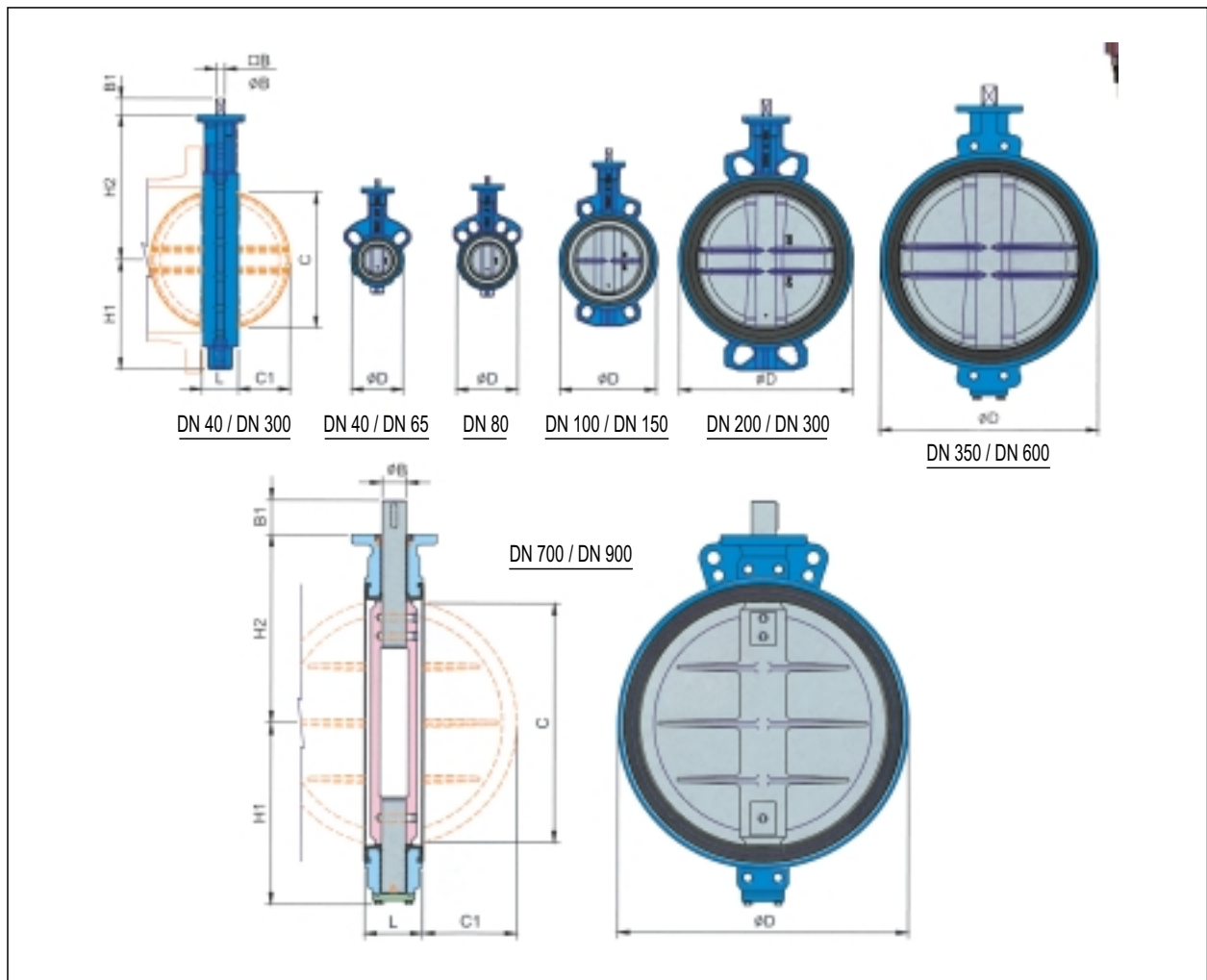

MISURA SIZE		SCARTAMENTO FACE TO FACE						FLANGIA SUPERIORE MOUNTING FLANGE (ISO 5211)	FINITURA DELL'ASTA SHAFT END			CHIAVE KEY	INGOMBRO DEL DISCO DISC CLEARANCE	PESO WEIGHT
mm	inch		L	H1	H2	D	Type	PCD	ø B	□ B	B1		C	C1
40	1 1/2	33	60	120	81	F07	70	14	11	19		34	7	2
50	2	43	65	143	96	F07	70	14	11	19		39	8	3
65	2 1/2	46	71	155	110	F07	70	14	11	19		55	13	3.8
80	3	46	77	162	124	F07	70	14	11	19		69	19	4
100	4	52	107	181	148	F07	70	14	11	19		91	27	5.3
125	5	56	122	197	180	F07	70	18	14	19		115	36	7.3
150	6	56	104	210	206	F07	70	18	14	19		140	47	8.2
200	8	60	165	240	259	F10	102	22	17	24		186	68	13.5
250	10	68	201	286	320	F10	102	25	19	24		239	90	21.2
300	12	78	234	309	370	F10	102	28	22	24		288	111	32.5
350	14	78	301	329	412	F12	125	35	27	29		325	128	48
400	16	102	333	361	475	F12	125	35	27	29		375	143	60
450	18	114	358	393	530	F14	140	48	36	38		423	162	80
500	20	127	392	427	585	F14	140	48	36	38		473	182	125
600	24	154	454	492	687	F16	165	60	46	48		560	214	200
700	28	165	508	533	796	F16	165	70		110	18 x 12	655	255	395
750	30	190	543	568	856	F25	254	75		110	20 x 12	692	264	490
800	32	190	574	599	903	F25	254	75		110	20 x 12	736	285	580
900	36	203	632	660	1003	F25	254	85		110	24 x 16	841	331	730



DIMENSIONI DIMENSIONS

VF-733 LUG

DN 40 ~ DN 600

PRESSURE RATING:
 DN 40-300 **16 BAR**
 DN 350-600 **10 BAR**

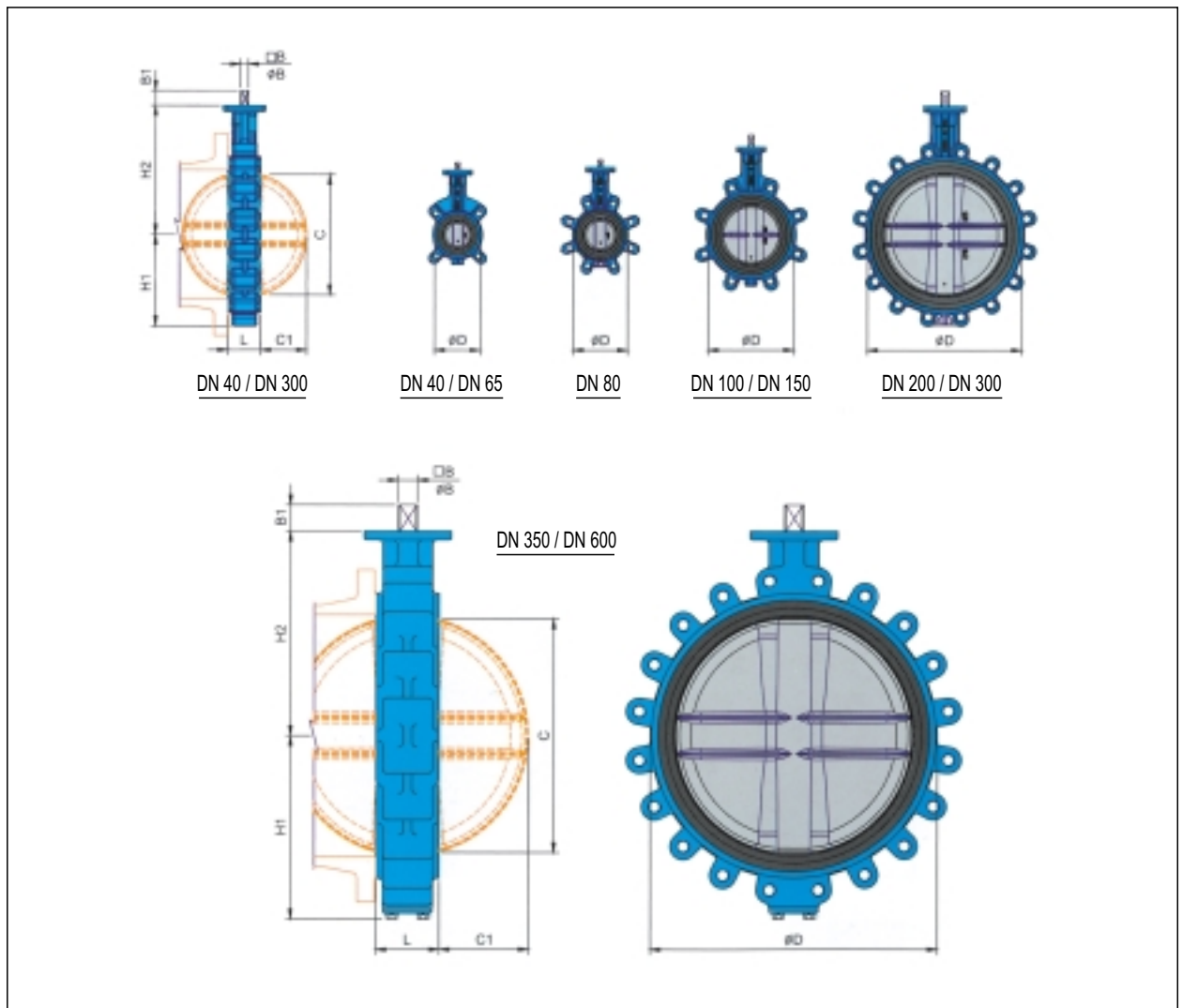

MISURA SIZE		SCARTAMENTO FACE TO FACE				FLANGIA SUPERIORE MOUNTING FLANGE (ISO 5211)		FINITURA DELL'ASTA SHAFT END			INGOMBRO DEL DISCO DISC CLEARANCE		PESO WEIGHT
mm	inch	L	H1	H2	D	Type	PCD	ø B	□ B	B1	C	C1	kg
40	1 1/2	33	60	120	81	F07	70	14	11	19	34	7	2.2
50	2	43	65	143	96	F07	70	14	11	19	39	8	3.4
65	2 1/2	46	71	155	110	F07	70	14	11	19	55	13	4
80	3	46	77	162	124	F07	70	14	11	19	69	19	4.5
100	4	52	89	181	148	F07	70	14	11	19	91	27	7.6
125	5	56	112	197	180	F07	70	18	14	19	115	36	9.5
150	6	56	123	210	206	F07	70	18	14	19	140	47	10.4
200	8	60	150	240	259	F10	102	22	17	24	186	68	17.5
250	10	68	179	286	320	F10	102	25	19	24	239	90	26.5
300	12	78	216	309	370	F10	102	28	22	24	288	111	43.5
350	14	78	301	329	412	F12	125	35	27	29	325	128	58
400	16	102	333	361	475	F12	125	35	27	29	375	143	81
450	18	114	358	393	530	F14	140	48	36	38	423	162	110
500	20	127	392	427	585	F14	140	48	36	38	473	182	155
600	24	154	454	492	687	F16	165	60	46	48	560	214	259



DIMENSIONI DIMENSIONS

VF-737 FLANGE

DN 500 ~ DN 900

PRESSURE RATING:
DN 500-900 **10 BAR**

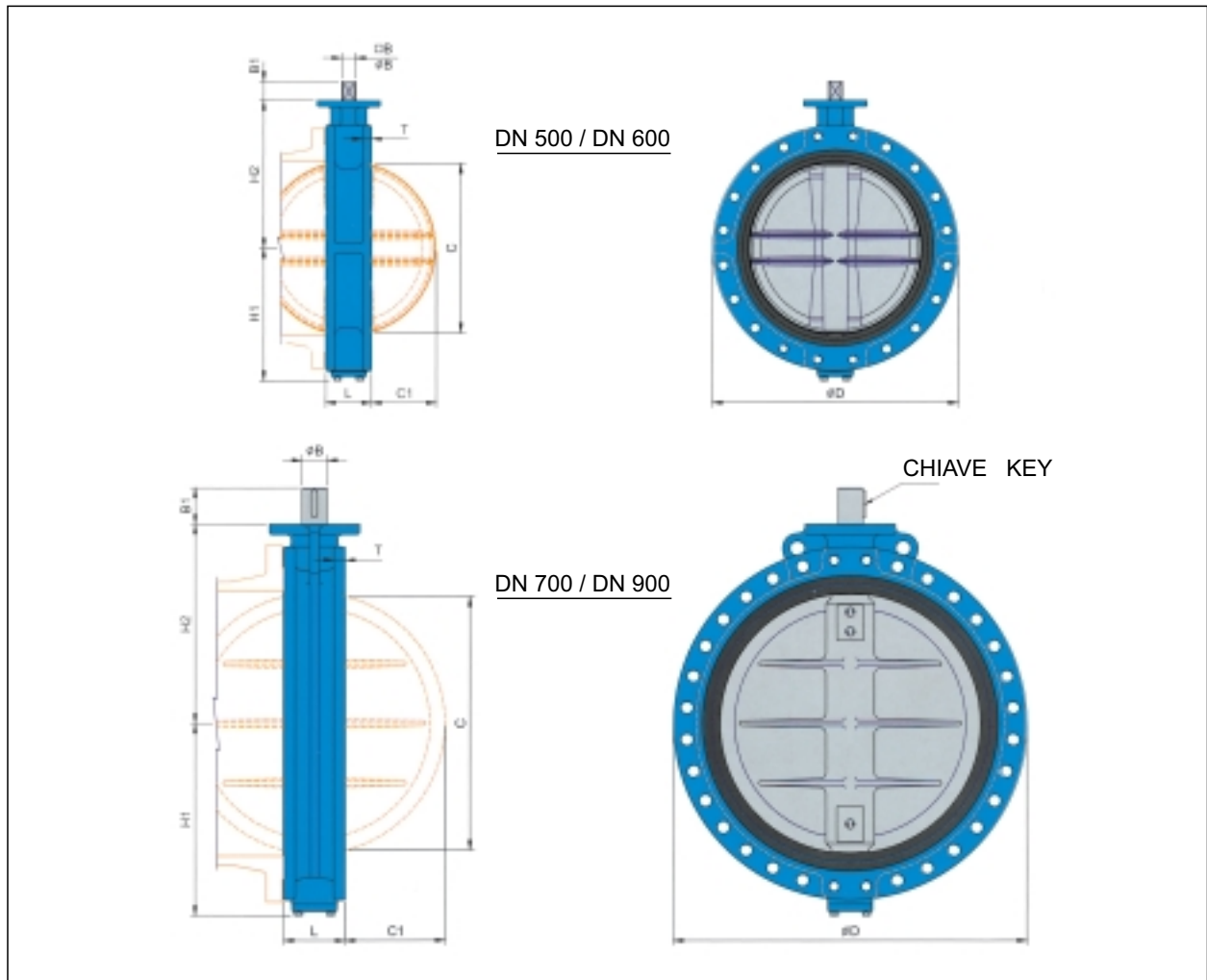

MISURA SIZE		SCARTAMENTO FACE TO FACE					FLANGIA SUPERIORE MOUNTING FLANGE (ISO 5211)		FINITURA DELL'ASTA SHAFT END			CHIAVE KEY	INGOMBRO DEL DISCO DISC CLEARANCE		SPESSORE DELLA FLANGIA THICKNESS OF FLANGE	PESO WEIGHT
mm	inch		L	H1	H2	D	Type	PCD	□ B	B1	ø B		C	C1	T	kg
500	20	127	392.5	427	715	F14	140	50	36	38		473	182	30	190	
600	24	154	454.4	492	840	F16	165	60	46	48		560	214	36	260	
700	28	165	508	533	927	F16	165	70		110	18 x 12	655	255	40	380	
750	30	190	543	568	997	F25	254	75		110	20 x 12	692	264	40	480	
800	32	190	574	599	1060	F25	254	75		110	20 x 12	736	285	44	540	
900	36	203	632	660	1170	F25	254	85		110	24 x 16	841	331	46	700	



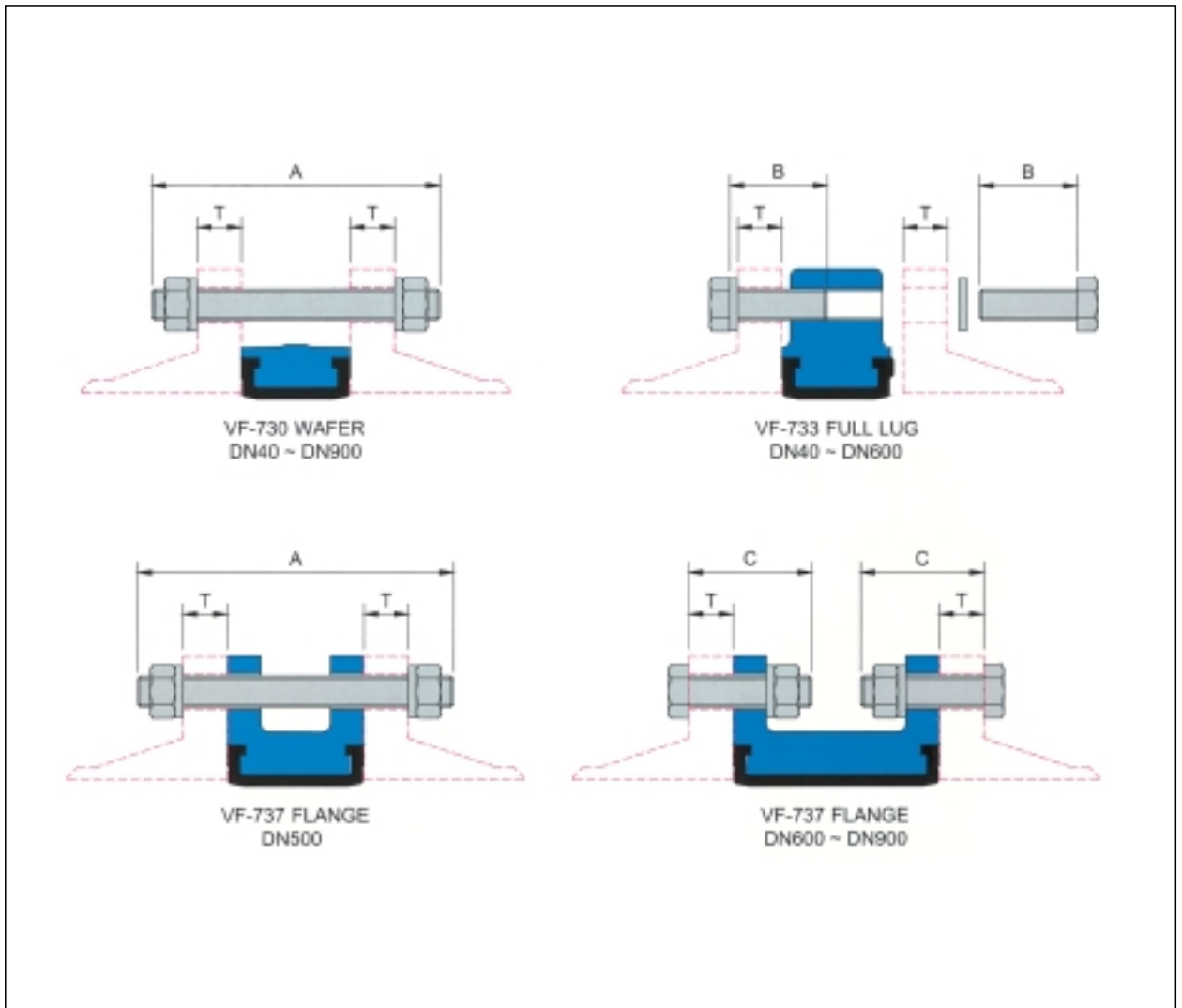

MISURA SIZE		PN 10					PN 16					ASME B16.5 CLASS 150 ASME B16.47 CLASS 150 SERIES A				
mm	inch	BULLONE BOLT	A	B	C	T	BULLONE BOLT	A	B	C	T	BULLONE BOLT	A	B	C	T
40	1 1/2	M16	115	35		18	M16	115	35		18	1/2"	105	35		18
50	2	M16	130	40		20	M16	130	40		20	5/8"	125	40		19
65	2 1/2	M16	130	45		20	M16	130	45		20	5/8"	135	45		22
80	3	M16	130	45		20	M16	130	45		20	5/8"	140	45		24
100	4	M16	140	50		22	M16	140	50		22	5/8"	145	50		24
125	5	M16	145	50		22	M16	145	50		22	3/4"	155	55		24
150	6	M20	160	55		24	M20	160	55		24	3/4"	160	55		25
200	8	M20	165	55		24	M20	160	55		24	3/4"	170	60		28
250	10	M20	175	60		26	M24	180	60		26	7/8"	185	65		30
300	12	M20	185	60		26	M24	195	70		28	7/8"	200	70		32
350	14	M20	185	60		26	M24	200	70		30	1"	215	75		35
400	16	M24	220	65		26	M27	235	80		32	1"	245	80		37
450	18	M24	235	70		28	M27	265	85		40	1 1/8"	265	85		40
500	20	M24	250	70		28	M30	290	100		44	1 1/8"	285	90		43
600	24	M27	295	80	100	34	M33	345	110	130	54	1 1/4"	330	100	120	48
700	28	M27	295		100	30	M33	325		120	38	1 1/4"	390		150	71
750	30											1 1/4"	420		150	75
800	32	M30	330		110	32	M36	355		120	38	1 1/2"	445		170	81
900	36	M30	345		110	34	M36	370		130	40	1 1/2"	475		180	90

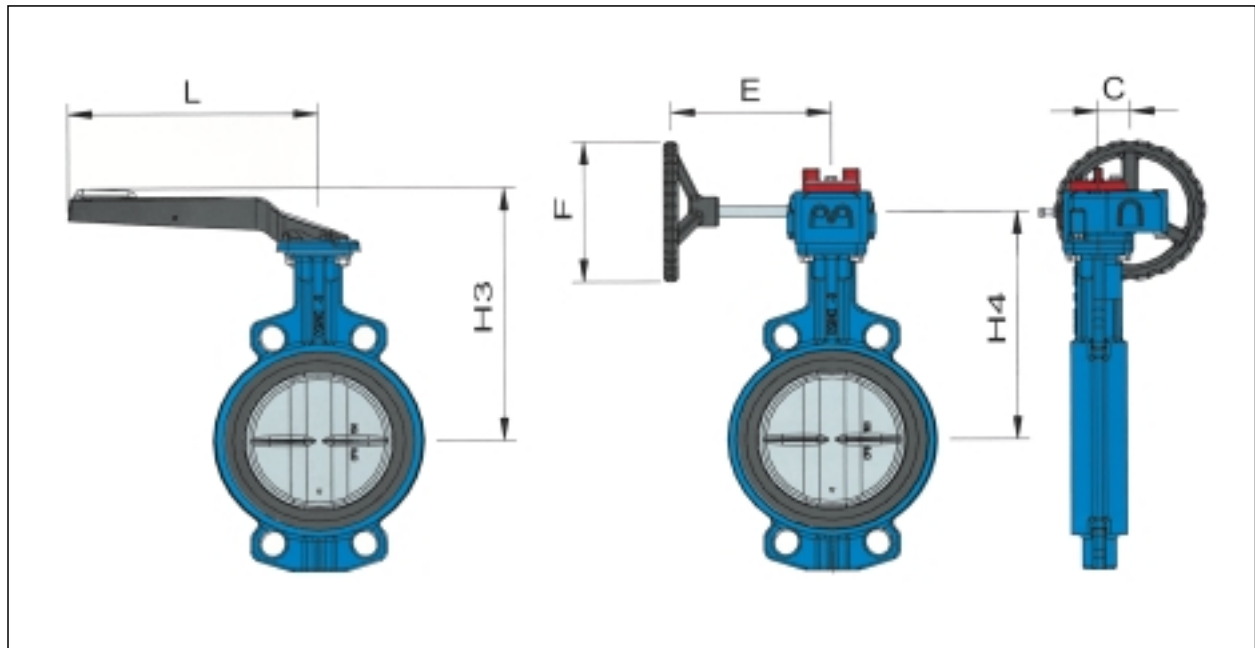

MISURA SIZE		CODICE DEL COMANDO OPERATOR SERIES no.	LEVA LEVER OPERATOR		RIDUTTORE AD INGRANAGGI GEAR OPERATOR				GIRI DI VOLANTINO HANDWHEEL TURNS ON/OFF	FLANGIA SUPERIORE MOUNTING FLANGE (ISO 5211)	
mm	inch		H3	L	H4	C	E	F		Type	PCD
40	1 1/2	L 7A	181	200						F07	70
		C 07			157	41	155	150	10		
50	2	L 7A	204	200						F07	70
		C 07			180	41	155	150	10		
65	2 1/2	L 7A	216	200						F07	70
		C 07			192	41	155	150	10		
80	3	L 7A	223	200						F07	70
		C 07			199	41	155	150	10		
100	4	L 7A	242	200						F07	70
		C 07			218	41	155	150	10		
125	5	L 7B	258	250						F07	70
		C 07			234	41	155	150	10		
150	6	L 7B	271	250						F07	70
		C 07			247	41	155	150	10		
200	8	L 10	308	355						F10	102
		C 10			281	63	195	200	9		
250	10	L 10	354	355						F10	102
		C 10			327	63	195	200	9		
300	12	L 10	377	355						F10	102
		C 10			350	63	195	200	9		
350	14	C 12			370	61	232	310	9	F12	125
400	16	C 12			402	61	232	310	9	F12	125
450	18	C 14			445	81	280	400	13	F14	140
500	20	C 14			479	81	280	400	13	F14	140
600	24	A2			548	123	307	400	17.5	F16	165
700	28	A2			589	123	307	400	17.5	F16	165
750	30	A3+S3			713	160	370	400	52.5	F25	254
800	32	A3+S3			713	160	370	400	52.5	F25	254
900	36	A3+S3			805	160	370	400	52.5	F25	254

Valori Kv Kv values-Valve sizing coefficient

MISURA SIZE		ANGOLO D'APERTURA DISC ANGLE (OPEN DEGREE)								
mm	inch	10°	20°	30°	40°	50°	60°	70°	80°	90°
40	1 1/2	0.7	2.4	6.9	14.2	22	36	59	81	113
50	2	1.1	3.8	10.2	22	38	60	100	132	193
65	2 1/2	2	7.5	18.2	35	61	95	187	240	315
80	3	2.5	9.8	26	48	83	126	214	338	425
100	4	3.8	14.6	39	72	119	221	361	606	723
125	5	6.5	24	62	118	217	394	599	1038	1243
150	6	10	41	95	175	326	542	873	1260	1859
200	8	19	64	165	306	573	995	1567	2310	3124
250	10	28	101	245	451	836	1462	2253	3256	4757
300	12	34	129	312	615	1137	2125	3248	4991	7058
350	14	47	163	390	795	1498	2573	3980	5749	8319
400	16	62	231	508	1077	1973	3381	5385	8099	11458
450	18	75	256	621	1208	2315	3925	6331	9474	13612
500	20	103	346	859	1692	3086	5348	8513	13109	18748
600	24	139	494	1153	2389	4466	7561	11945	18088	25217
700	28	191	659	1674	3224	5990	10659	17442	25194	36821
750	30	203	700	1777	3420	6354	11307	18503	26727	39062
800	32	257	973	2302	4533	8235	14123	23021	31613	45995
900	36	329	1253	2950	5862	10810	18184	29756	42893	61044

Kv identifica i valori di flusso in mc/h per acqua a 20°C alla pressione differenziale di 1 kg/cmq. Se necessario Cv=1.17 kv.
Kv values denotes flow rate in m³/hr for water at 20°C flowing under a differential pressure 1 kg/cm². When require Cv=1.17 kv.

Torsione operativa (Nm) Operating torque (Nm)

MISURA SIZE		LUBRIFICATE (non corrosivo) LUBRICATING (non-corrosive) ΔP (bar)				ASCIUTTE (non lubrificate) DRY (non-lubricating) ΔP (bar)		
mm	inch	3	6	10	16	3	6	10
40	1 1/2	15	17	19	23	19	21	23
50	2	15	17	19	23	19	21	23
65	2 1/2	18	20	22	26	22	24	27
80	3	28	31	34	41	34	38	42
100	4	37	41	45	54	45	50	56
125	5	61	68	76	91	76	84	93
150	6	116	127	140	154	126	138	152
200	8	171	190	211	253	211	234	260
250	10	275	306	340	408	340	378	420
300	12	381	423	470	564	470	522	580
350	14	545	605	672		672	747	830
400	16	728	809	899		899	999	1110
450	18	912	1013	1126		1126	1251	1390
500	20	1135	1261	1401		1401	1557	1730
600	24	1325	1472	1636		1636	1818	2020
700	28	2339	2599	2888		2888	3209	3566
750	30	2608	2898	3220		3220	3578	3975
800	32	3008	3342	3713		3713	4125	4583
900	36	3828	4253	4726		4726	5251	5834

Per usare la tabella prendere nota di quanto segue:

- 1) I valori di torsione includono anche la frizione (attrito) per ciascun valore di Δp
- 2) Per calcolare le dimensioni dell'attuatore non è necessario applicare alcun fattore di sicurezza al valore di torsione indicato.

To use the torque chart, note the following:

- 1) Operating torque value above included friction bearing torque for stated Δp
- 2) Do not apply a safety factor to above torque values when determining actuator output torque requirement.

