

Cast Iron 3-Way Ball Valve

Flanged PN16, T-Port or L-Port, PTFE Seats



Pressure/Temperature Ratings	
Max Pressure	16 Bar
Temperature	-10°C to +120°C

Material List		
1	Body	Cast Iron
2	Ball Seat	Teflon
3	Ball with Stem	CF8
4	Seat Ring Holder	Cast Iron
5	O-Ring	PTFE
6	Retainer	Cast Iron
7	Stem Packing	Teflon
8	Gland Flanged	Cast Iron
9	Gland Bolt	SS 41
10	Top Cover	Cast Iron
11	Joint Gasket	Teflon
12	Handle	Cast Iron

Torque (Breakaway) without Safety	
50mm	54.1 Nm
65mm	83.5 Nm
80mm	96.43 Nm
100mm	199.90 Nm
150mm	470.40 Nm

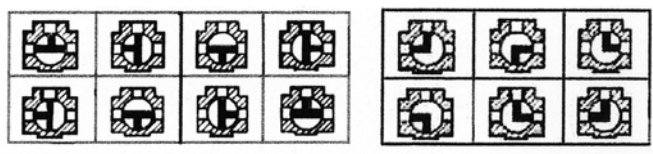
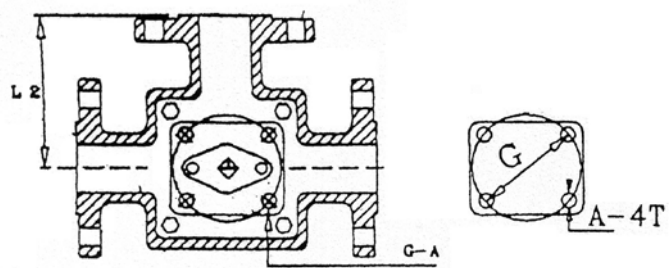
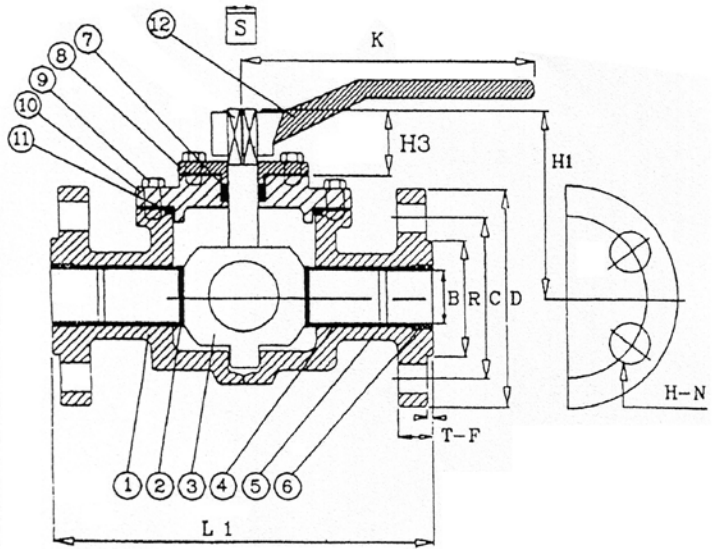

Dimension List Pn16 DIN-3202		L1	L2	B	D	T	R	F	C	H	N	H1	H3 FC	H3 304	K	S	A	G	Kg T	Kg L
Valve Size																				
mm	inch																			
50	2"	220	110	49	165	18	102	2	125	18	4	130	46	53	235	16	M10	70	18	18.6
65	2½"	250	125	83	185	18	122	2	145	18	4	150	55	65	340	19.5	M10	102	28	29.0
80	3"	260	130	74	200	20	138	2	160	18	8	160	60	61	340	19.5	M10	102	29	31.0
100	4"	340	170	100	220	20	158	2	180	18	8	180	55	56	340	19.6	M10	102	47	49.0
150	6"	435	217.6	150	285	22	212	2	240	22	8	240		75	510	25	M12	126	103	105