

Check Valves are self acted by the media pressure and are devised to prevent the flow return to the pressurized side of the system. Spring loaded Disc Check Valves are featured as a light and economic option to be used on industrial plants. Its wafer design suitable to installation between flanges makes these valves quite a light option but still of a rugged construction. The disc loaded by a spring stops the fluid and prevents it from returning to the pressurized side of the installation.

Disc guides of integral casting, more reliable than conventional bolted styles.

Spring protector cap of austenitic steel, high reliability.

Smooth finish facing to provide better tightness.

Grooved centering ring to accommodate the assembling bolts

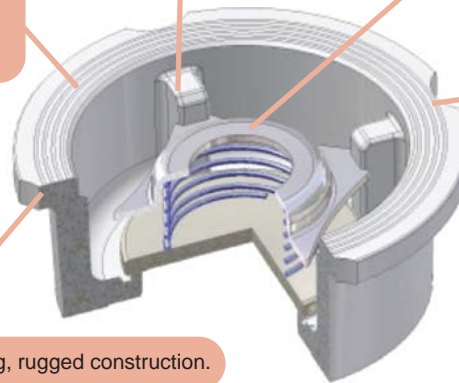

Integral centering ring, rugged construction.

Self Acting Non return valves * Closure element by spring loaded disc, of axial movement* Leakage Rate 0 (resilient seats) – Rate 1 (metal seats)* Unidirectional Design (observe direction of arrow on valve commissioning) * Minimal Opening Pressure: (observe chart of values depending on size and installation position) * Standard Design pressure: PN 40 / ANSI 300 (from DN 15 up to DN 100) made to specific standard on larger sizes: (PN 16/25/40/64/100 – ANSI 150/300/600/900)* Size range: DN 15-350* Design Temperatures: 400°C with metal seats, in the event of resilient seat the temperature is restricted by the elastomeric material (refer to data sheet)* face to face length as per EN 558 S49 (DIN 3202 K4) for sizes up to DN 200 and S52 (DIN 3202 K5) for larger sizes * Standard installation between flanges EN 1092 PN 6/40, ANSI 150/300 standard for valve sizes up to DN 100, flange standard to be specified on larger valve sizes* Tests EN 12266-1* EN 19 Marking standard * Approval PED 97/23/CE

Main Parts and Materials

PART	MATERIAL	BODY OPTIONS			DISC OPTIONS			SEALING OPTIONS			
		MATERIAL	DIN N°	CODE	MATERIAL	DIN N°	CODE	MATERIAL	TEMPERATURE	CODE	
1	Body	STEEL	1,7264	27	ST. STEEL	1,4301	11	EPDM	-55°C A 150°C	E	
2	Disc	BRONZE	2,1050	33	AUSTENITIC	1,4435	64	NBR	-40°C A 110°C	P	
3	Spring Holder	AUSTENITIC	1,4409	64	AUSTENITIC	1,4301	65	VITON	-20°C A 200°C	V	
4	Spring	AUSTENITIC	1,4301	65	Mo FREE	URANUS	1,4539	68	PTFE	-200°C A 200°C	T
5	Sealing	Mo FREE	URANUS	1,4539	68	TITANIUM	3,7035	90	METAL (STANDARD)	ACCORDING TO MATERIAL	M
		TITANIUM	3,7035	90	HASTELLOY B	2,4600	94				
		HASTELLOY B	2,4600	94	HASTELLOY C	2,4819	95				
		HASTELLOY C	2,4883	95							

Main Valve Dimensions (mm)

DN (mm)	15	20	25	32	40	50	65	80	100
DN (pulg.)	½"	¾"	1"	1¼"	1½"	2"	2½"	3"	4"
Ød1	15	20	25	32	39	48	62	72	89
ØD1	44	54	63	73	83	96	116	132	152
ØD2	51	61	71	80	92	107	127	142	168
L	16	19	22	28	31,5	40	46	50	60

DN (mm)	125	150	200	250	300	350
DN (inch)	5"	6"	8"	10"	12"	14"
ØD1, PN10	192	218	273	328	378	438
ØD1, DN16	192	218	273	328	378	444
ØD1, D2, PN25	192	226	283	338	400	457
ØD1, D2, PN40	192	226	290	352	417	474
ØD1, D2, ANSI150	192	218	273	338	400	447
ØD1, D2, ANSI300	212	247	304	352	417	482
L	90	106	140	200	250	280

Opening Pressures

DN (mm)	15	20	25	32	40	50	65	80	100
DN (inch)	½"	¾"	1"	1¼"	1½"	2"	2½"	3"	4"
ΔP↑	25	25	25	27	28	29	30	31	33
ΔP→	20	20	20	20	20	20	20	20	20
ΔP↓	15	15	15	13	12	11	10	9	7

DN (mm)	125	150	200	250	300	350
DN (inch)	5"	6"	8"	10"	12"	14"
ΔP↑	37	40	46	69	73	73
ΔP→	22	25	28	42	44	44
ΔP↓	7	10	10	15	15	15

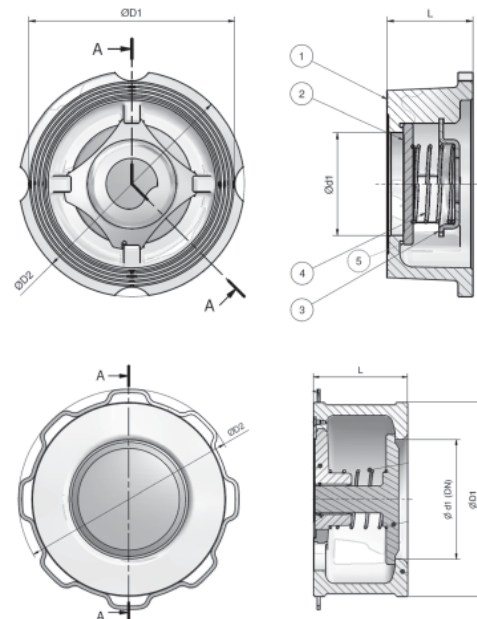

Main Duties

Hot and cold water * Saturated and Overheated Steam * Lubricating Media* Process media (even corrosive)