

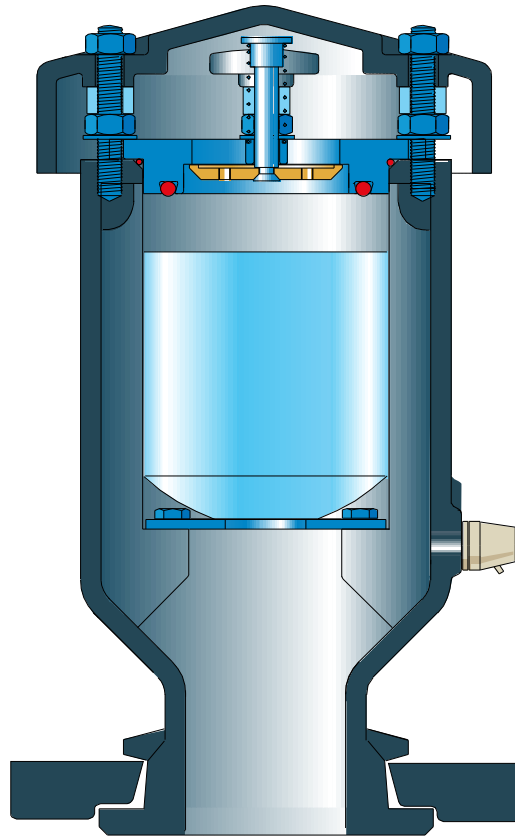

Water anti-shock air valve Mod. FOX 2F AS

The air valve will ensure the proper operation of the pipeline networks allowing the entrance of large amounts of air in case of draining or pipeline burst, and the discharge with controlled speed thanks to an exclusive AS mechanism.



Construction and advantages

- **Full bore, ductile iron valve body** provided with internal ribs for consistent and accurate float assembly guiding.
- **Drainage valve** for chamber control and draining.
- **Maintenance** can be easily performed from the top without removing the air valve from the pipe.
- **Float Assembly** comprises a polypropylene main cylindrical float and upper automatic orifice float.
- **Anti Shock automatism** composed of a metallic disk with 2 or more small orifices, a guide bar and a counteracting spring in stainless steel.

Operating principle

1) Entrance of large volumes of air

During pipeline draining or bursting phases it is necessary to bring in as much air as the quantity of out-flowing water to avoid vacuum conditions.

2) Controlled air discharge

The FOX 2F- AS air valve is provided with a mechanism called AS. During vacuum conditions the mobile block is laid over the diffuser, the antishock disk comes down pulling the stainless steel spring and allowing the entrance of a large volume of air through the main orifice to compensate for the vacuum effect.

For air flow performances of FOX 2F-AS please refer to the chart depicted on the next page.

(*) Full polypropylene cylindrical floats to avoid deforming phenomena at high pressure and lathe shaped to guarantee:
a) a greater sliding precision inside the body processed ribs;
b) a perfectly vertical thrust;



Air flow performance charts.

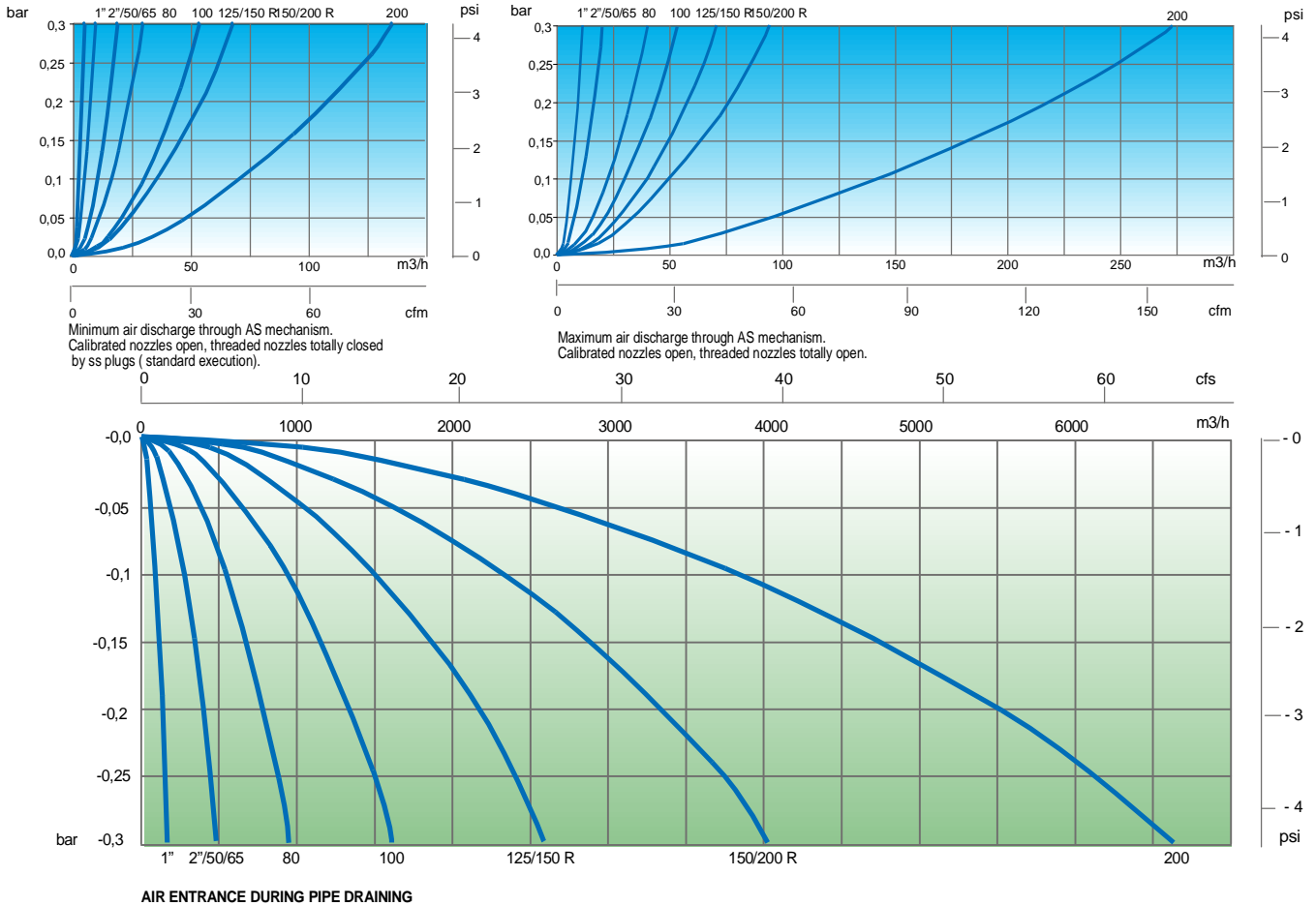

Working conditions

Potable water 70°C/ 158 °F Max; Maximum pressure 40 bar/ 580 psi; Minimum pressure 0.3 bar/ 4.35 psi

Technical features

Body, cover and flange

GS 400-15 epoxy powder coated using FBT technology

Seat in stainless steel/bronze/anticorodal

AS guide bar and spring in stainless steel

AS disk in brass

Float in polypropylene

Nuts and bolts in stainless steel

Gaskets in NBR

Drainage valve in brass for 16 bar/ 232 psi, stainless steel for 25 bar/ 362 psi and 40 bar/ 580 psi.

EXECUTION	A	B	C	D	Weight
Threaded 1"	113	205	=	CH45	3,7
Threaded 2"	142	260	=	CH75	6,4
Flanged 50	142	275	165	=	8,3
Flanged 65	142	275	185	=	9
Flanged 80	174	300	200	=	12,4
Flanged 100	217	350	220	=	20,5
Flanged 125-150R	267	425	250	=	37,5
Flanged 150-200R	325	490	285	=	49
Flanged 200	414	565	340	=	95

